

This manual must be kept with the appliance

October 2010

Solar Collector (Evacuated Tube)

Installation Guide, Operation & Maintenance Manual



Working towards
a cleaner future



The content of this manual was correct at the time of print. Andrews Water Heaters reserves the right to change technical details without prior notice. Warranty conditions are void if the instructions of this manual are not being followed when installing the system. This manual refers to the installation of the product only. If any doubt arises during the installation, please contact point of purchase immediately.



Contents

1	General Instructions	4
2	Overall View of Installation Types	7
2.1	Sloping Roof Kit Vertical	8
2.2	Sloping Roof Kit $>2.5\text{kN/m}^2$	10
2.3	Sloping Roof Kit 20° Elevated	12
2.4	Metal Roof Kit Vertical	14
2.5	Metal Roof Kit 20° Elevated	16
2.6	Sloping Roof Kit Horizontal	18
2.7	Surface Mount 35° to 55°	20
2.8	Surface Mount 35° to 55° $>2.5\text{kN/m}^2$	22
2.9	Surface Mount 0° & 90° Vertical	24
2.10	Surface Mount 90° Horizontal	26
3	Installation Steps	28
4	Installation of Accessory Kits	55
4.1	Connection	56
4.2	Interconnection	57
4.3	Air-Separator	60
5	Installation of Tubes	62
5.1	Direct Flow Evacuated Tubes	63

1 General Instructions



1 General Instructions

Scope of Manual

Please note that this manual refers only to the installation of the Evacuated Tube Collectors. Andrews Water Heaters reserves the right to change this document and its content without notice.

This manual is for the trained installer only. Before commencing the installation please ensure to:

- read this manual carefully
- check the contents of the goods received against the packing lists included with the product
- set-up and provide required safety equipment
- have all tools available
- complete other plumbing and electrical work as far as possible to avoid unnecessary no load exposure of system to solar radiation

Use of Manual

This manual describes the installation procedure for the Andrews Water Heaters direct flow evacuated tube collectors on all available roof kits including their connection to the pipe work. The manual is structured in such a way, that the various installation options are shown in overall view diagrams (2.1 to 2.10), which refer to detailed installation steps as denoted by letters (A1 to J2). The overall view drawing section is followed by the detailed drawing section through which you are guided by individual numbers for each step.

Symbols

The following symbols are being used throughout the manual and indicate only the meaning given below:

	Step		Diagram		Pencil		Drill Bit Metal 3mm
	Description		Spanner 13mm		Level		Drill Bit Masonry 10mm
	Part No.		Spanner 17mm		Safety Equipment		
	Quantity		Tape Measure		Drill Bit Wood 5mm		

Safety Precautions

General

- ! The system is to be designed in accordance with the relevant local standards and regulations.
- ! The pipe work of the solar collector loop is to be earthed and the collector is to be lightning protected in accordance with local regulations.
- ! Before carrying out any electrical work ensure that mains is switched off and secured in off position while work is ongoing.
- ! Relevant personal protective equipment is to be used and worn at all stages of installation, commissioning, maintenance and dismantling of system.

Collector

- ! Transport tube and manifold boxes horizontally. Do not load heavy goods on top. Avoid scratching and sudden shocks to glass tubes, do not use sharp objects to open boxes.
- ! Unpack and install tubes only after the manifold unit has been installed and all pipe work completed.
- ! Do not leave the solar collector exposed to solar radiation without using the energy generated. Collectors left exposed in dry condition need to be covered to avoid possible long-term damage.
- ! Pipes running horizontally should always be installed at a slight rise towards the highest point vent point of the system to avoid air locking of the system.

Technical Details

	20 Tube Collector	30 Tube Collector
Dimensions (Length x Width x Height) [mm]	1996 x 1418 97	1996 x 2127 x 97
Weight [kg]	54.8	81.4
Volume [l]	3.8	5.6
Max Field Size [m ²]	12	
CU Pipe Diameter [mm] (*)	2-3m ² 15 x 1 4-9m ² 22 x 1 10-15m ² 28 x 1.2 16-20m ² 35 x 1.5	
Max Operating Pressure [bar]	8	
Min. Slope [°]	0	
Max. Slope [°]	90	
Max. Load [kNm ²] (Din 1055-5)	2.5	
Heat Transfer Medium	Propylene Glycol suitable for evacuated tube collectors (Tyfocor LS)	

(*) Pipe diameters calculated for 0.1 l/min/tube and v_max = 0.5 m/s.

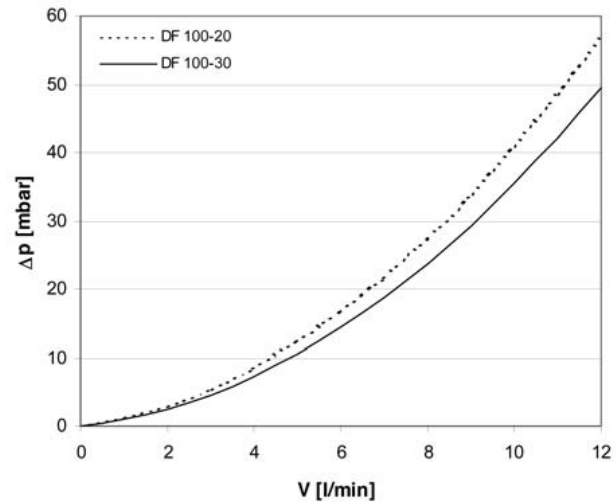

2 Overall View of Installation Types



2.1 Sloping Roof Kit Vertical

- A Attach lower brackets to roof.
- B Secure side rails to lower bracket.
- D Attach upper bracket to roof.
- E Secure side rails to upper brackets.
- I Locate manifold on side rails.
- J Locate support rails on side rails.



- A1
- B1
- D1
- E1
- I1
- J1



- x2
- x2
- x2
- x2
- x1
- x2

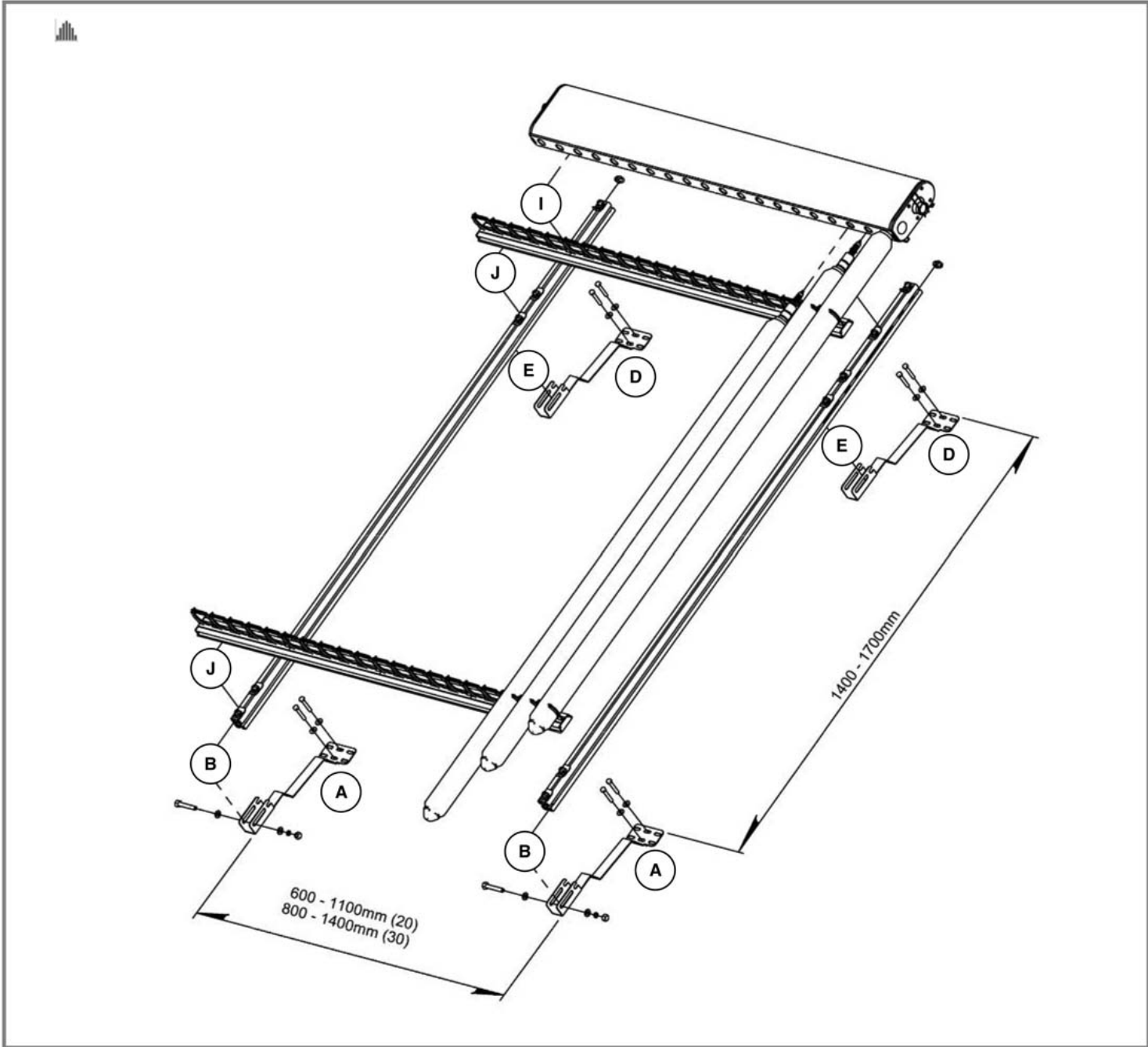

2.2 Sloping Roof Kit >2.5 kN/m² Vertical

- A Attach lower brackets to roof.
- B Secure side rails to lower bracket.
- D Attach upper bracket to roof.
- E Secure side rails to upper brackets.
- I Locate manifold on side rails.
- J Locate support rails on side rails.



- A1
- B1
- D1
- E1
- I1
- J1



- x3
- x3
- x3
- x3
- x1
- x2

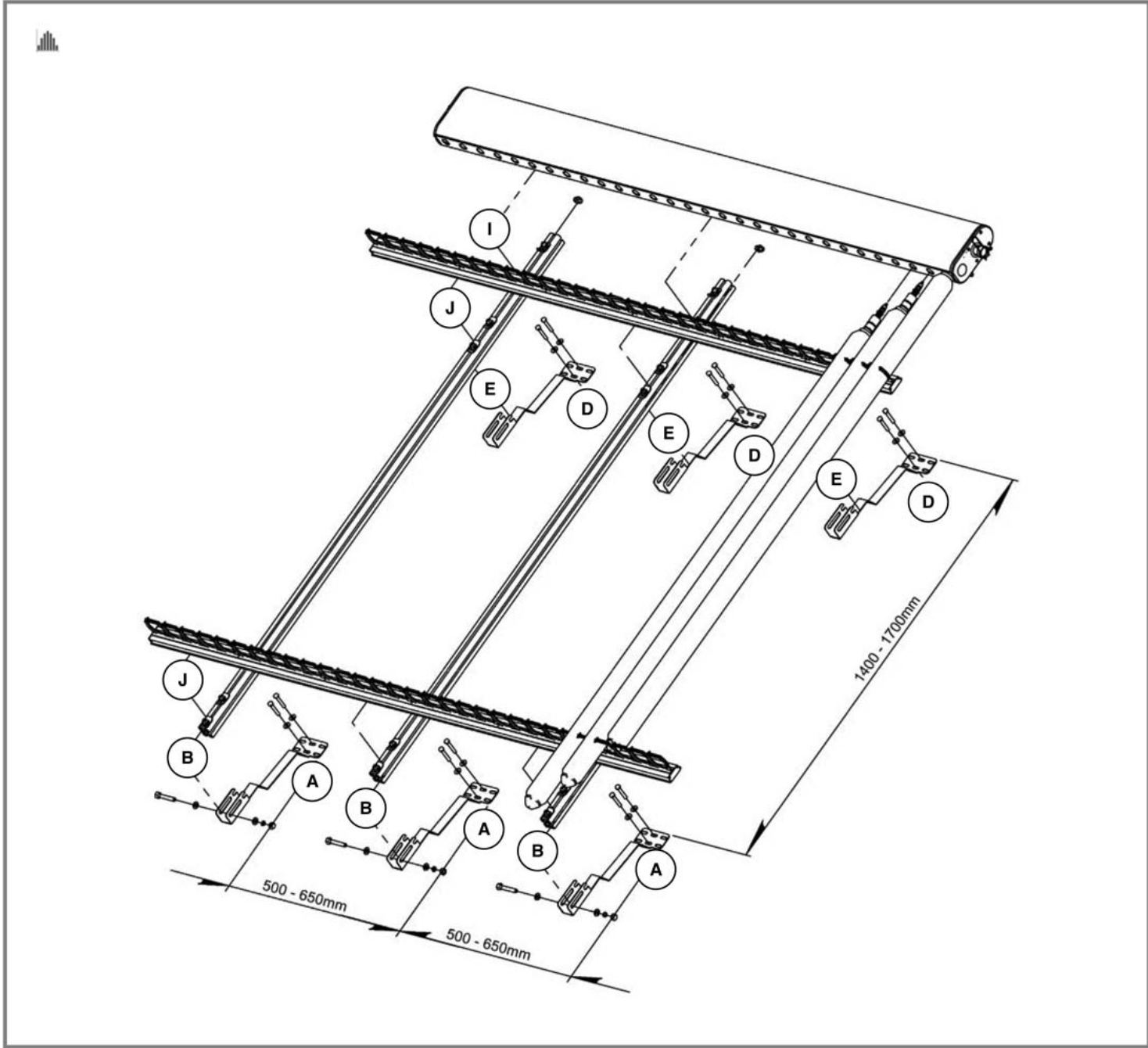

2.3 Sloping Roof Kit 20° Elevated

- A Attach brackets to roof at distance shown.
- B Assemble hinge brackets to roof brackets at distance shown.
- C Expand A-Sections.
- D Secure side rail to lower bracket.
- E Secure rear strut to upper bracket.
- F Adjust and secure side brace.
- G Attach and secure rear brace.
- I Locate manifold on side rails.
- J Locate support rails on side rails.



A2
B2



x4
x4
x2
x2
x2
x1
x1
x2

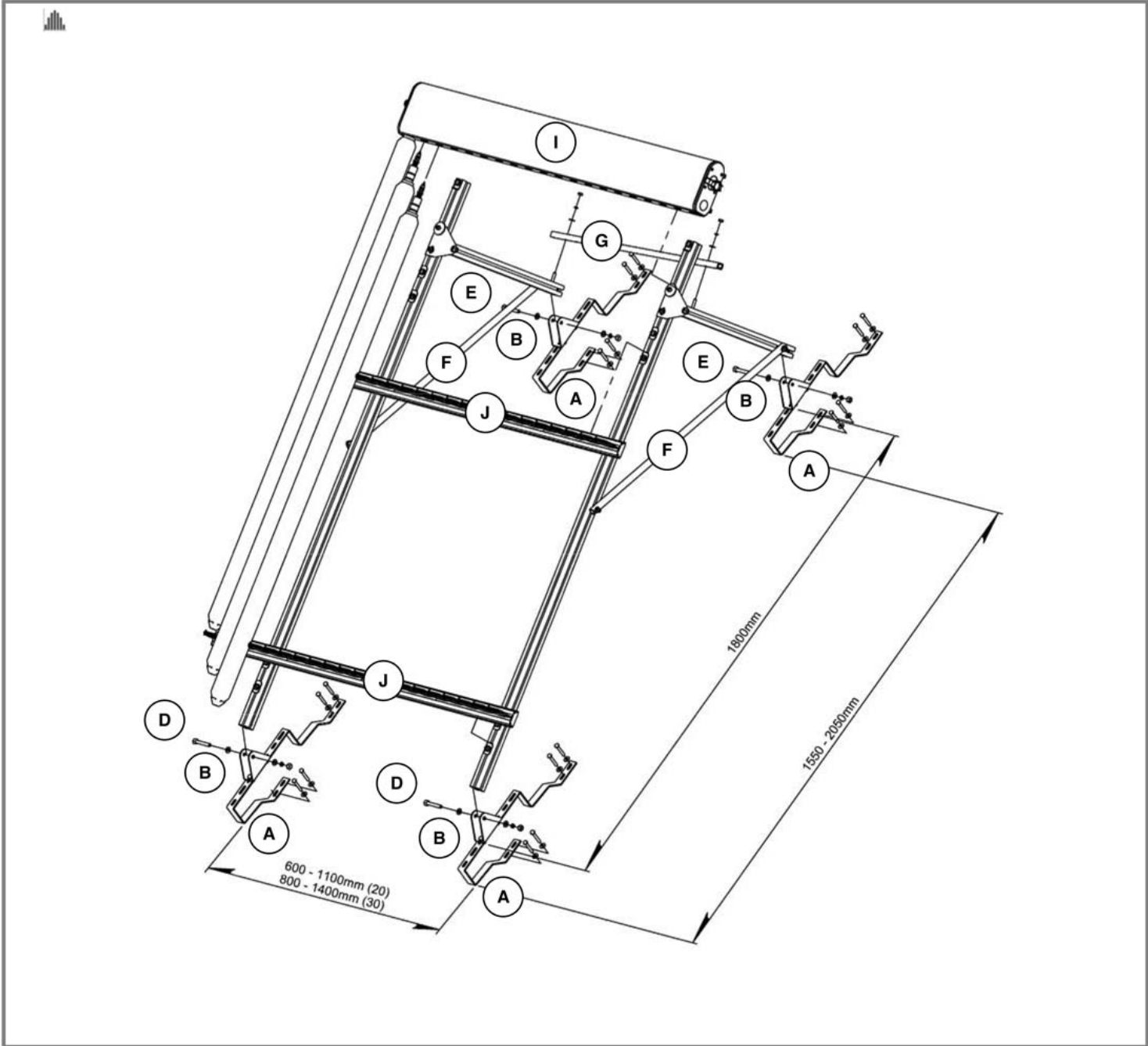

2.4 Metal Roof Kit (Vertical)

- B Attach side rails to pre-mounted bar on roof at distance shown.
- I Locate manifold on side rails.
- J Locate support rails on side rails.



B3
I1
J1



x2
x1
x2

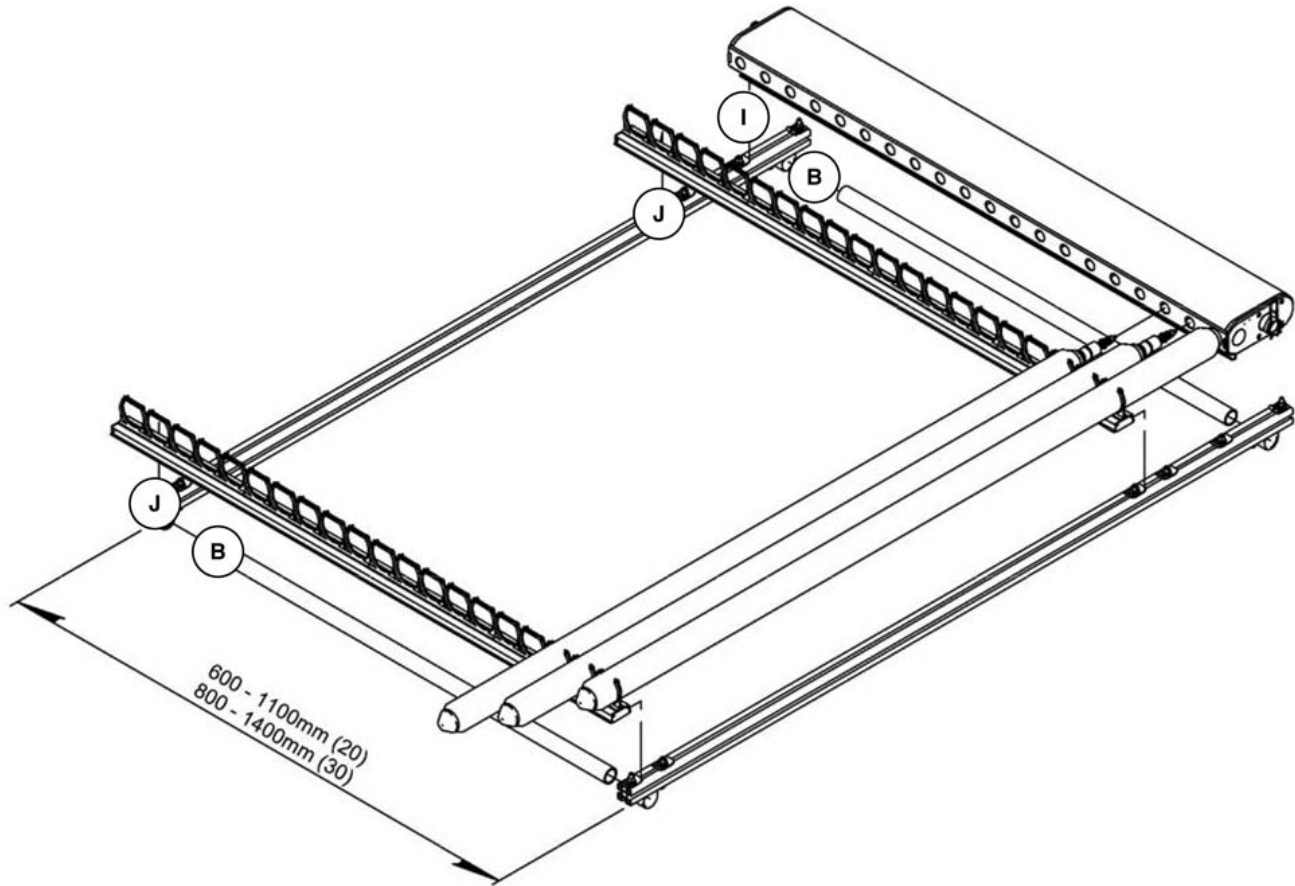

2.5 Metal Roof Kit 20° Elevated

A	Attach brackets to pre-mounted bar on roof at distance shown.	A3	x4
C	Expand A-Sections.		x2
D	Secure side rail to lower bracket.	D2	x2
E	Secure rear strut to upper bracket.	E2	x2
F	Adjust and secure side brace.	F1	x2
G	Attach and secure rear brace.	G1	x1
I	Locate manifold on side rails.	I2	x1
J	Locate support rails on side rails.	J1	x2

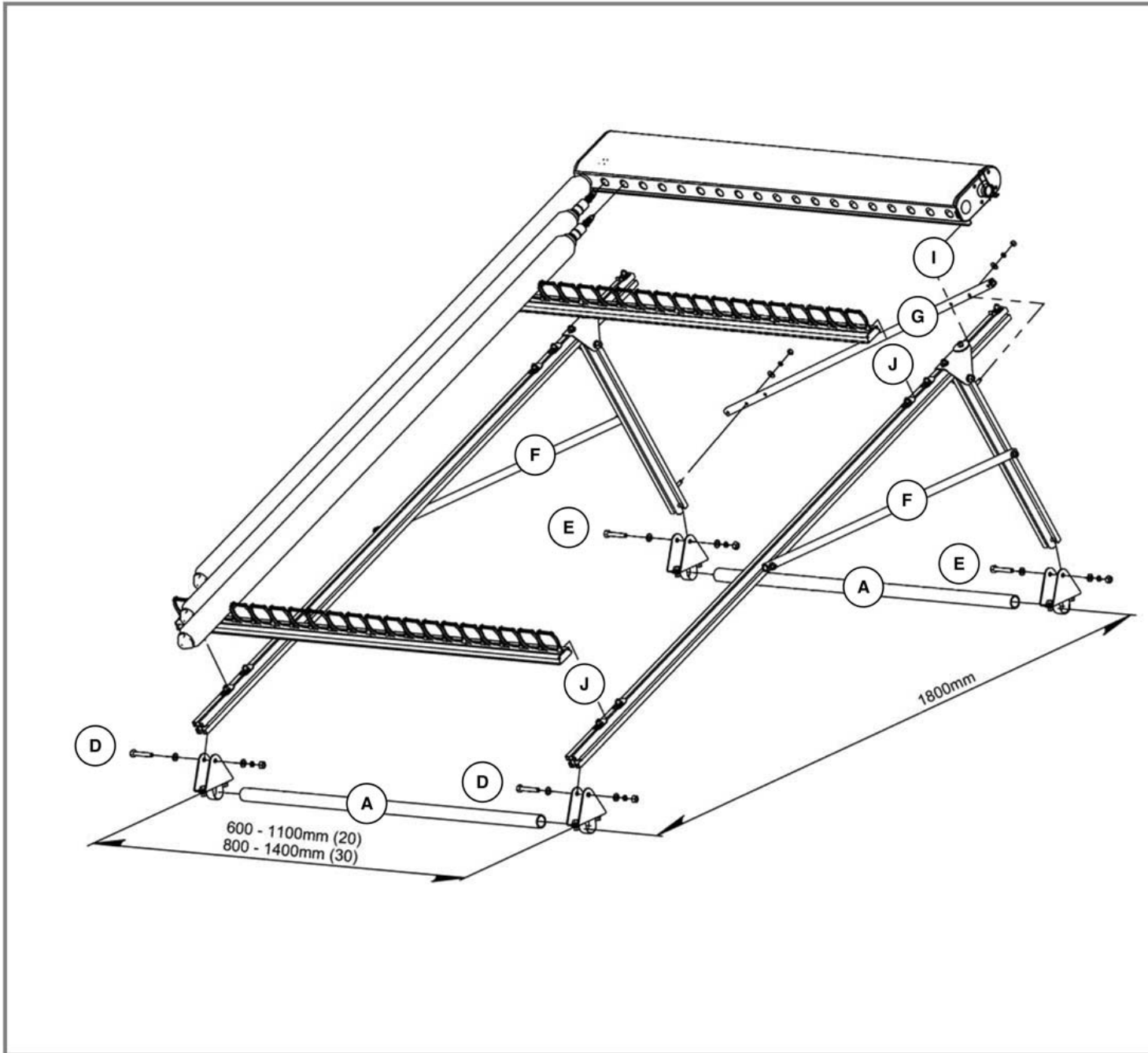

2.6 Sloping Roof Kit Horizontal

- A Attach brackets to roof at distance shown.
- D Secure side rails to brackets.
- H Locate locking pin positions and drill holes.
- I Locate manifold on side rails.
- J Locate support rails on side rails.

A4	x4
D3	x2
H	x3
I3	x1
J2	x2

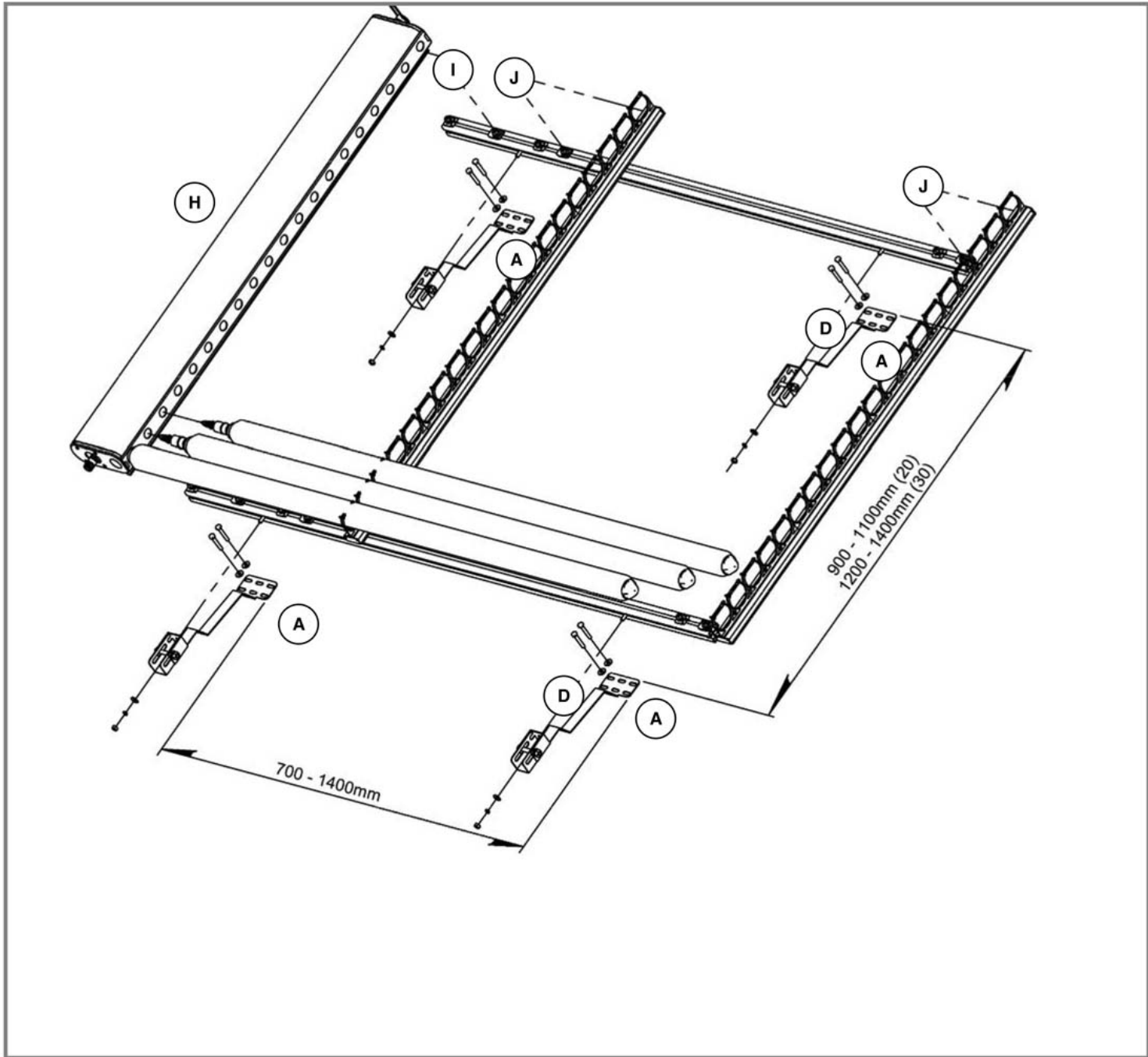

2.7 Surface Mount 35° to 55°

- A Attach front brackets to surface at distance shown.
- B Attach rear brackets to surface at distance shown.
- C Expand A-Sections.
- D Secure side rail to front bracket.
- E Secure rear strut to rear bracket.
- F Adjust and secure side brace.
- G Attach and secure rear brace.
- I Locate manifold on side rails.
- J Locate support rails on side rails.



A5
B4



x2
x2
x2
x2
x2
x1
x1
x2

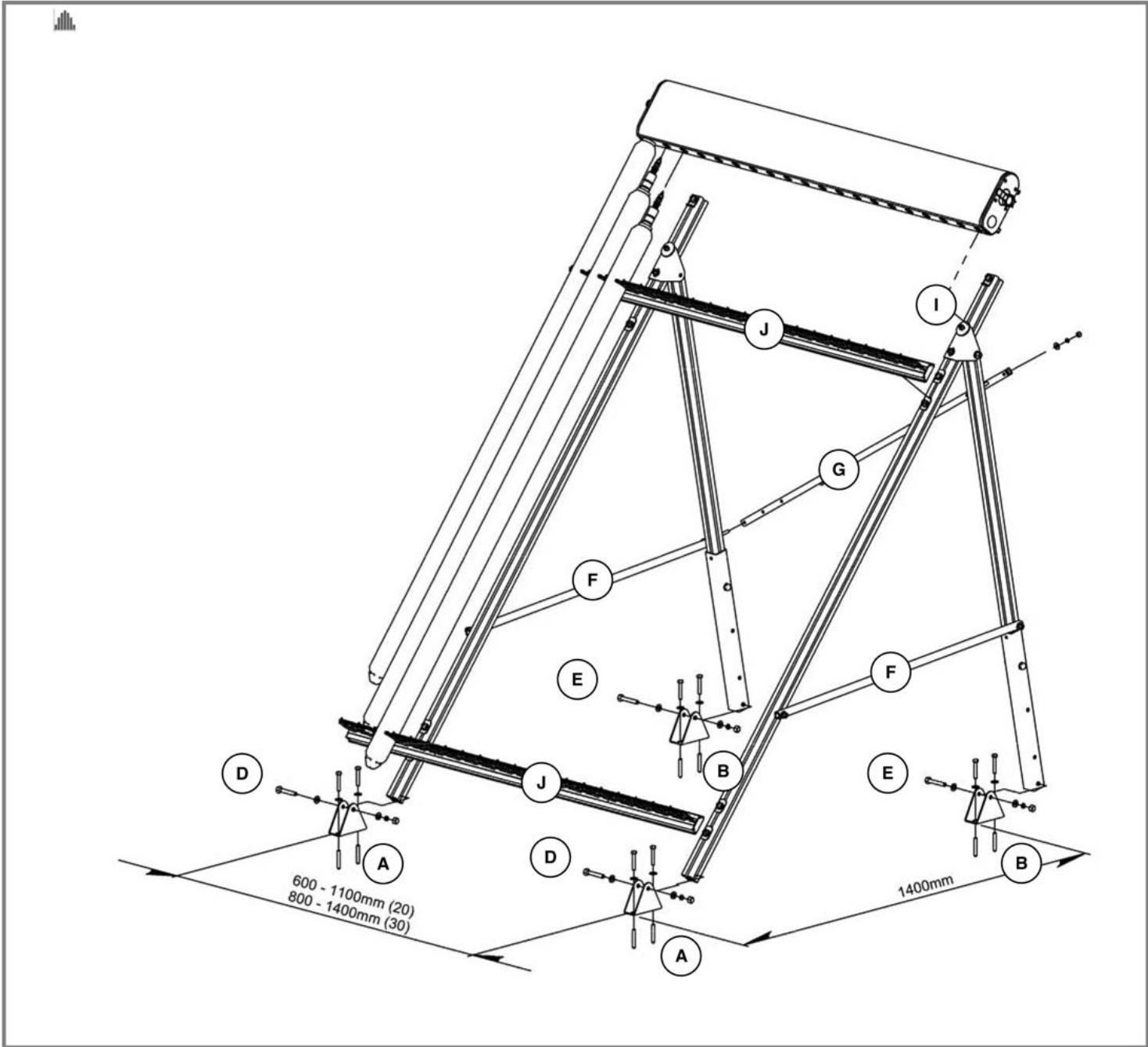

2.8 Surface Mount 35° to 55° >2.5 kN/m²

A	Attach front brackets to surface at distance shown.	A5	x3
B	Attach rear brackets to surface at distance shown.	B4	x3
C	Expand A-Sections.		x3
D	Secure side rail to front bracket.	D2	x3
E	Secure rear strut to rear bracket.	E3	x3
F	Adjust and secure side brace.	F2	x3
G	Attach and secure rear brace.	G2	x2
I	Locate manifold on side rails.	I2	x1
J	Locate support rails on side rails.	J1	x2

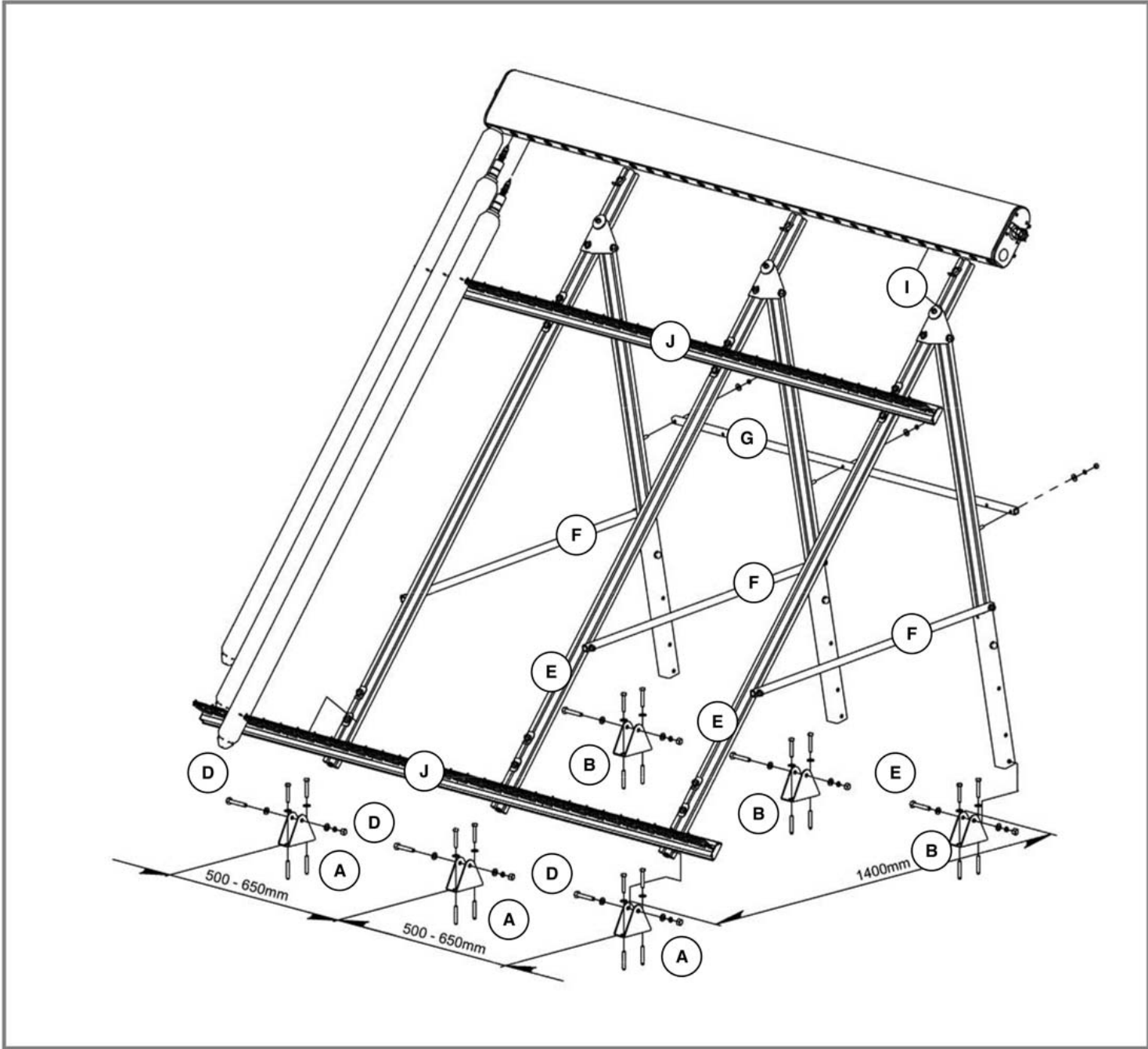

2.9 Surface Mount 0° & 90° Vertical

- A Attach brackets to surface at distance shown.
- D Attach side rails to brackets.
- I Locate manifold on side rails.
- J Locate support rails on side rails.

A5	x4
D4	x2
I1	x1
J1	x2

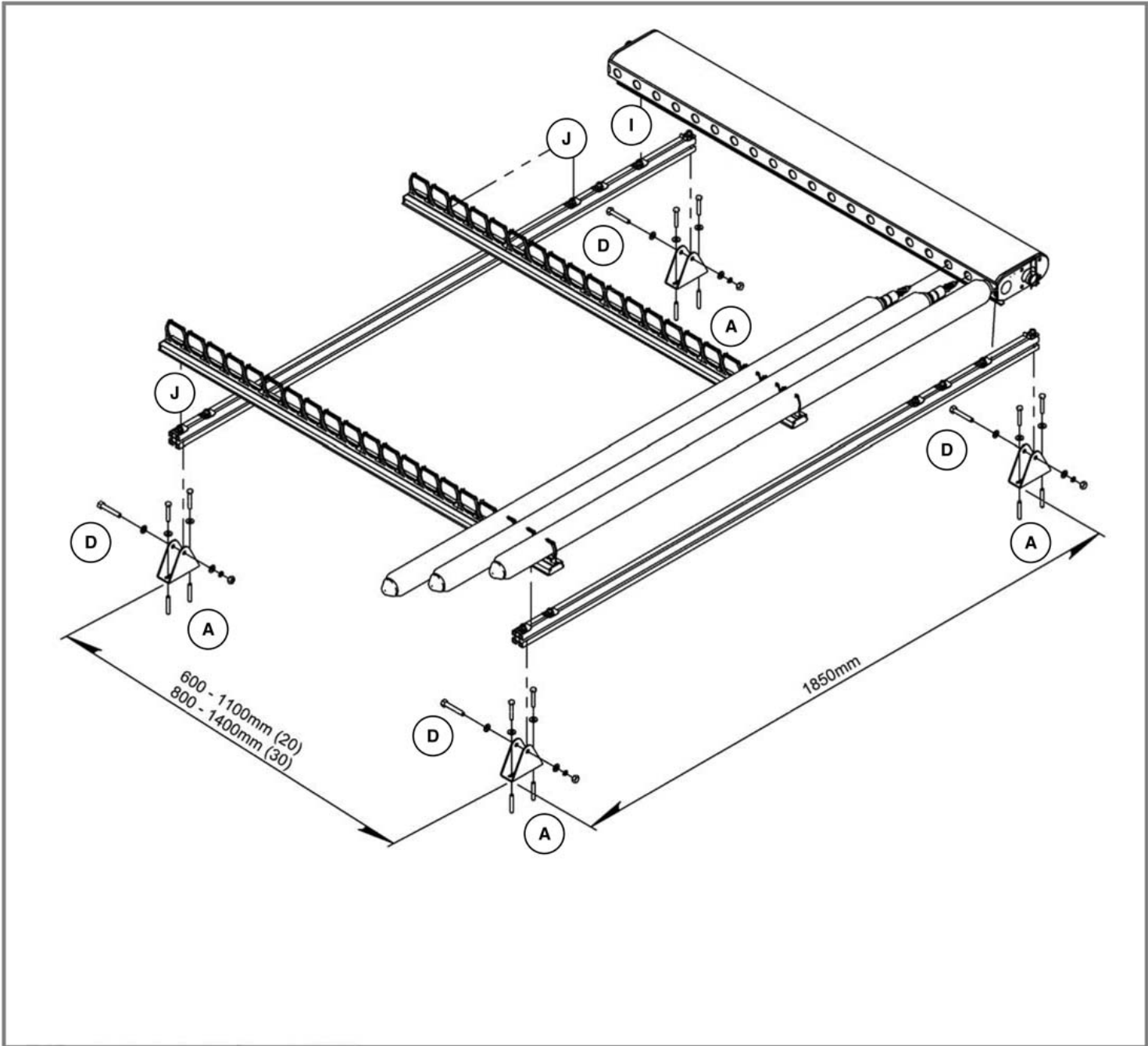

2.10 Surface Mount 90° Horizontal

- A Attach brackets to surface at distance shown.
- D Attach side rails to brackets.
- H Locate locking pin positions and drill holes.
- I Locate manifold on side rails.
- J Locate support rails on side rails.



A5
D4
H
I3
J2



x4
x2
x3
x1
x2

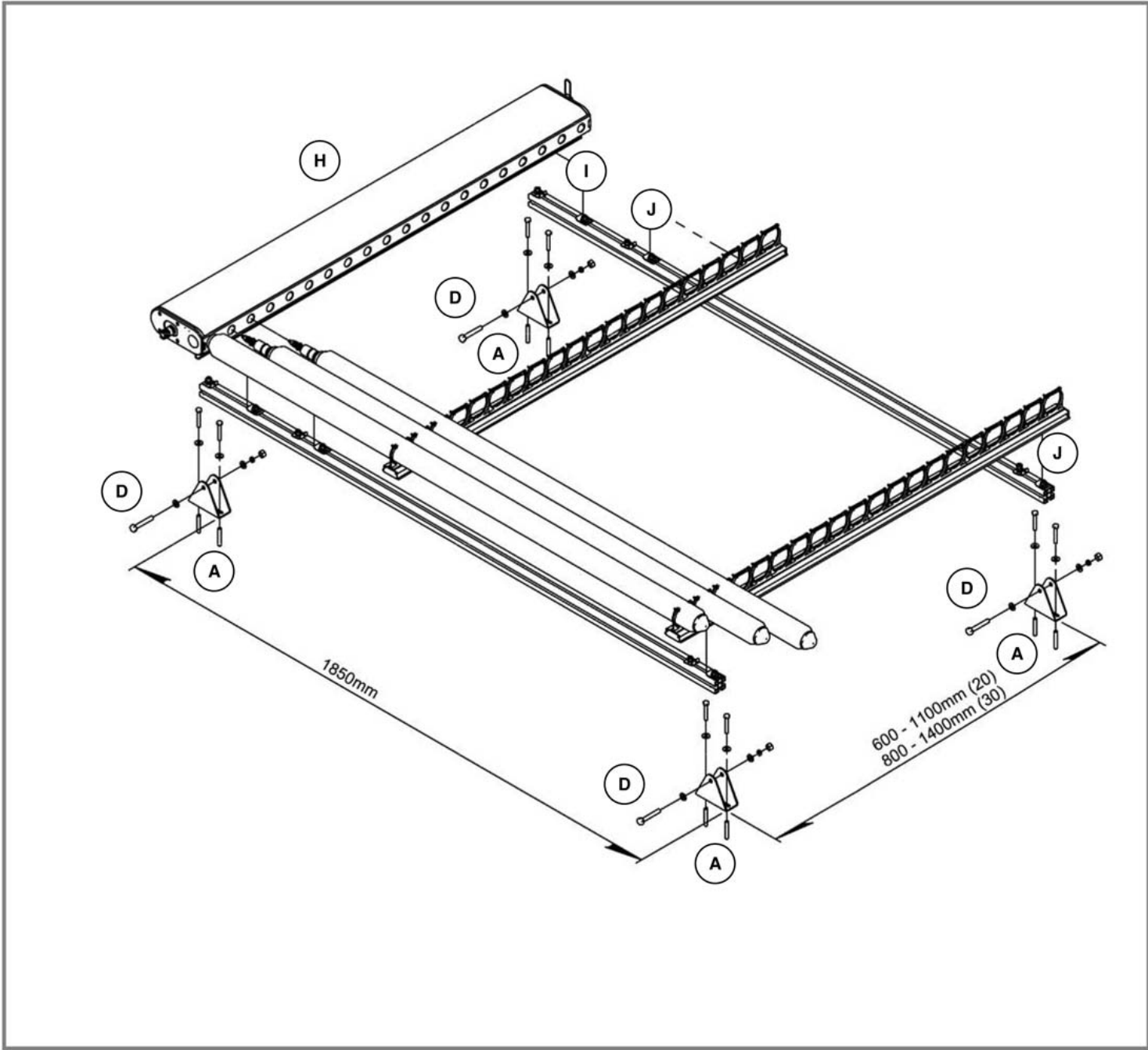

3 Installation Steps



A1

①			x1
②	B4331		x1
③			x2
④	A0168, A0170		x2
⑤			x1
⑥			
⑦			

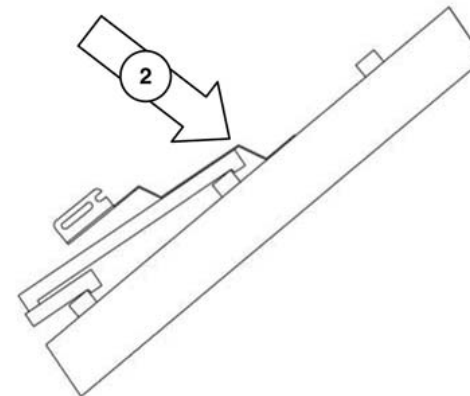
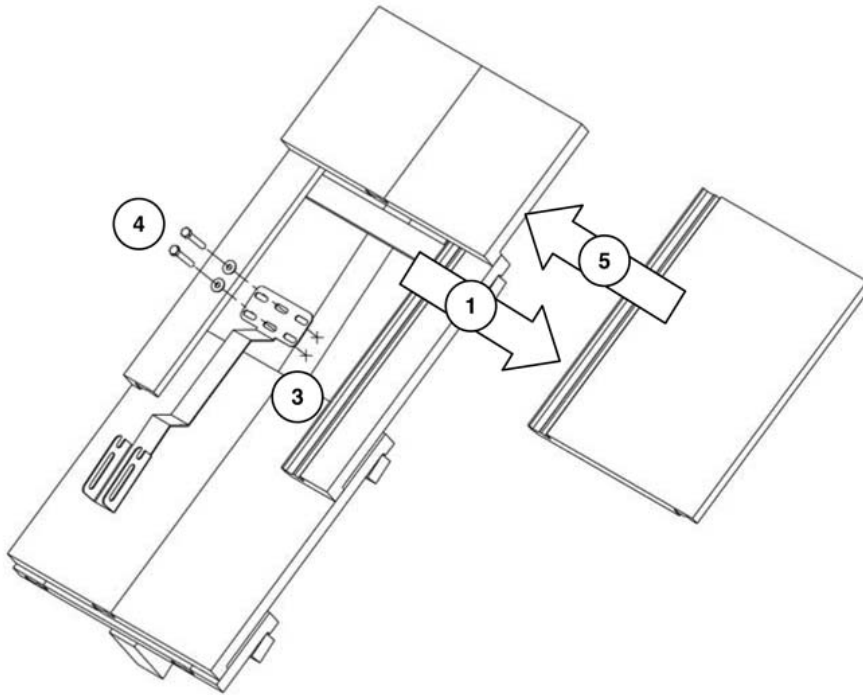

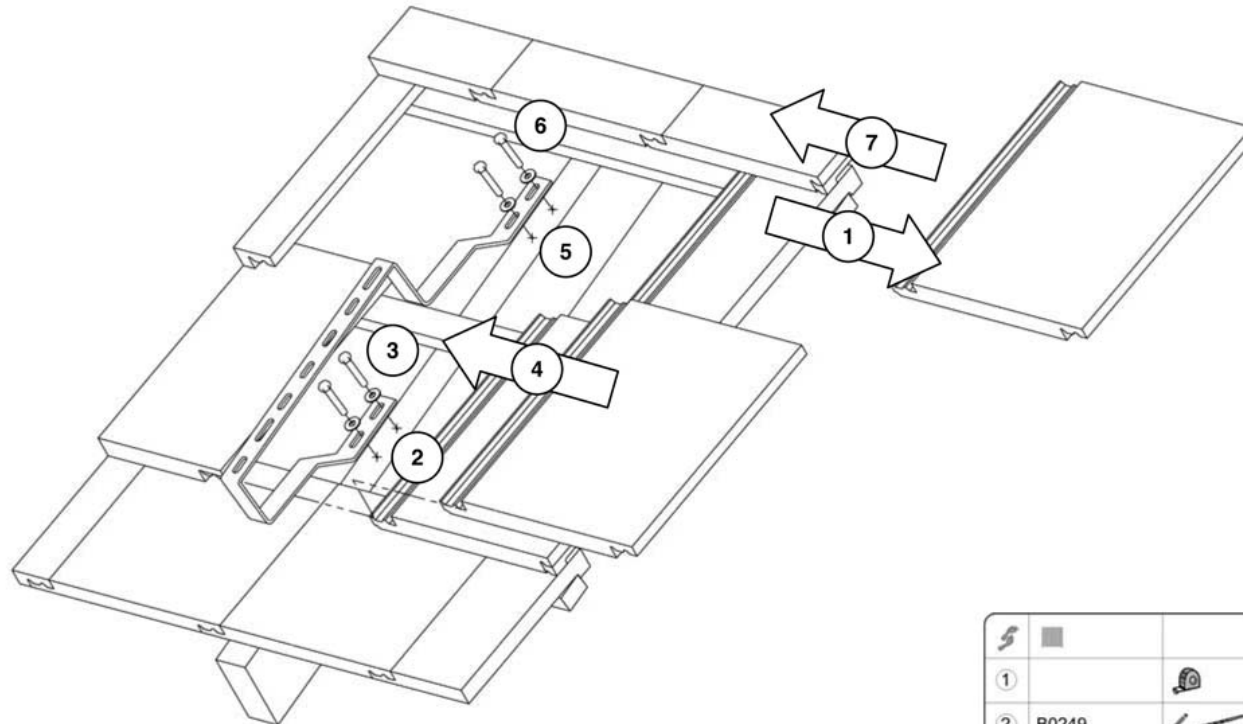

①	■	⚙️	⚖️
①			x1
②	B0249	 WS	x2
③	A0168, A0170	 13	x2
④			x1
⑤	B0249	 WS	x2
⑥	A0168, A0170	 13	x2
⑦			x1

 **A3**

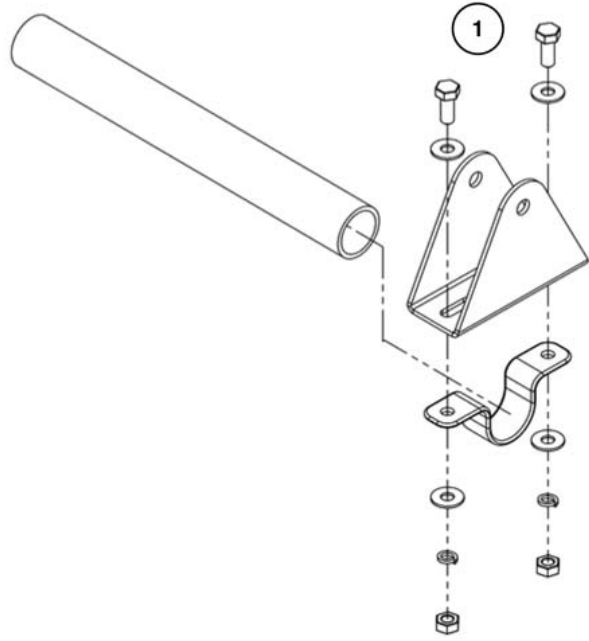

			
①	B4311, A0814, A1382, A0170, A0172, A0169, A2941	x1	
②			
③			
④			
⑤			
⑥			
⑦			

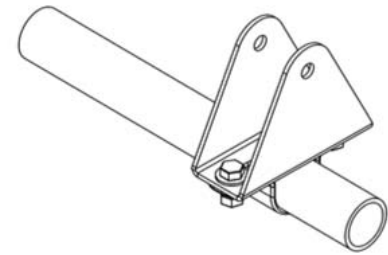

 A4

①			x1
②	A4447		x1
③		 W5	x2
④	A0168, A0170	 13	x2
⑤			x1
⑥			
⑦			

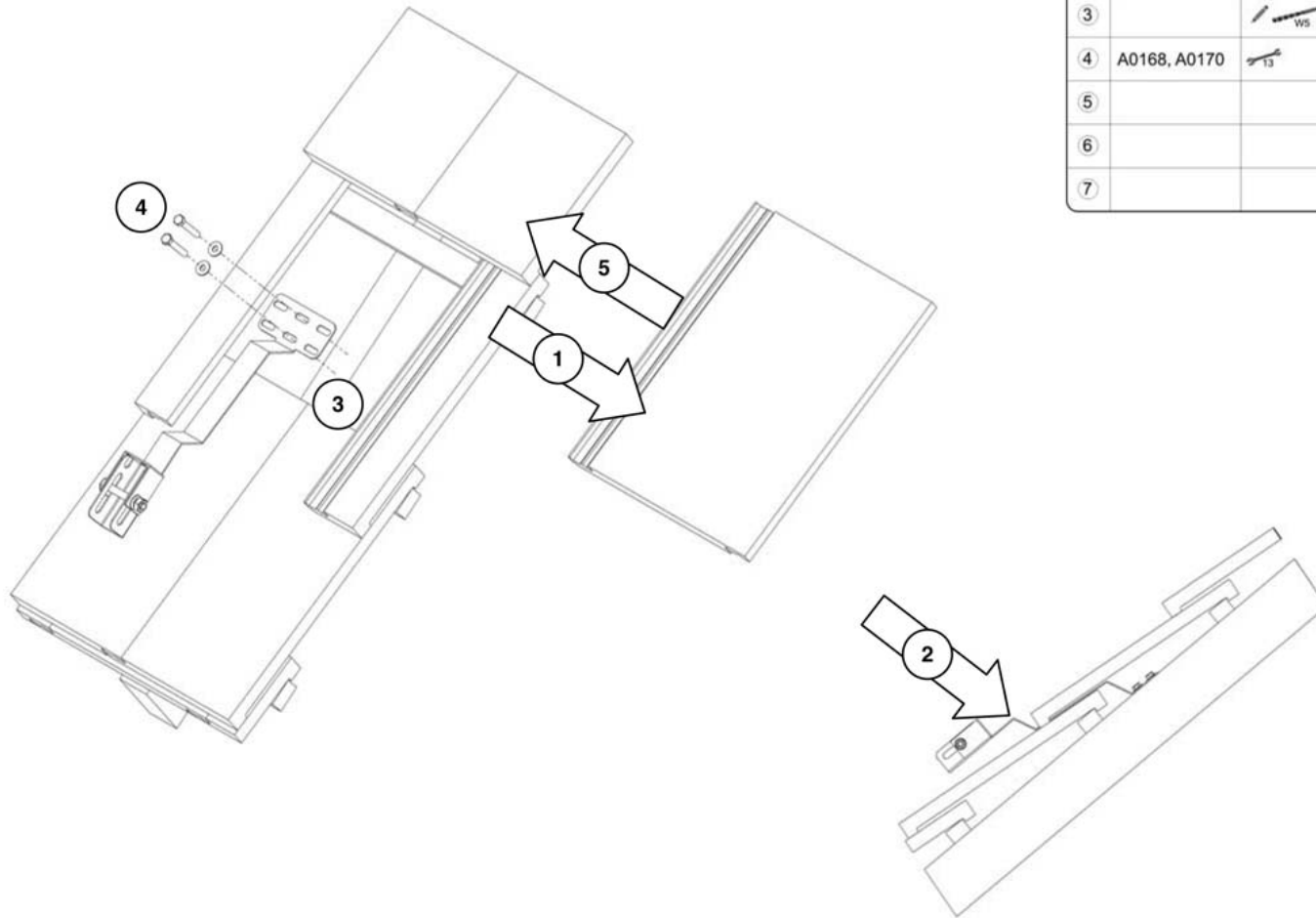

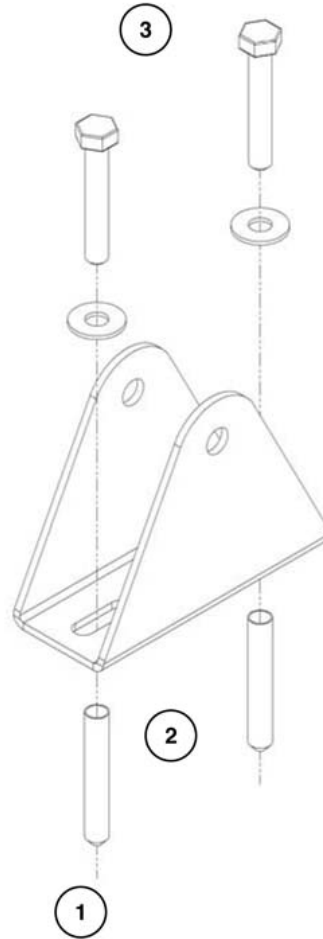

A5

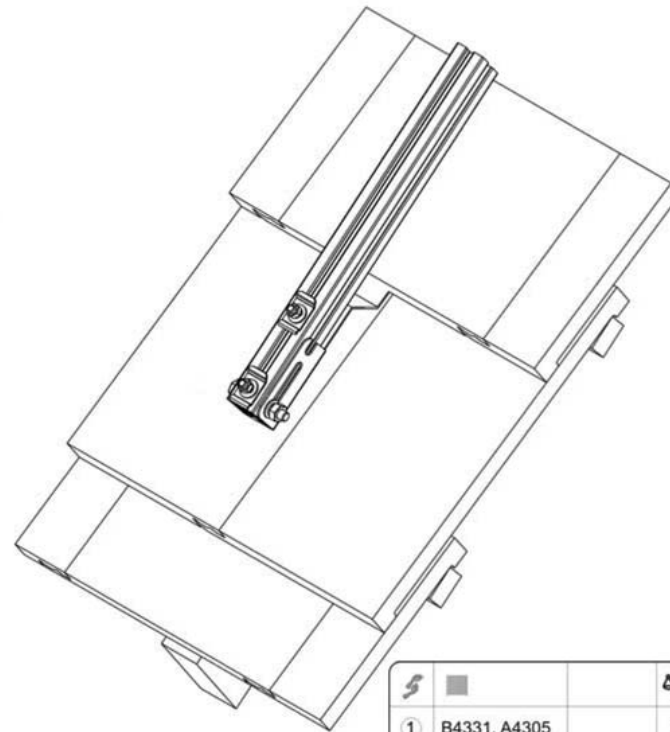
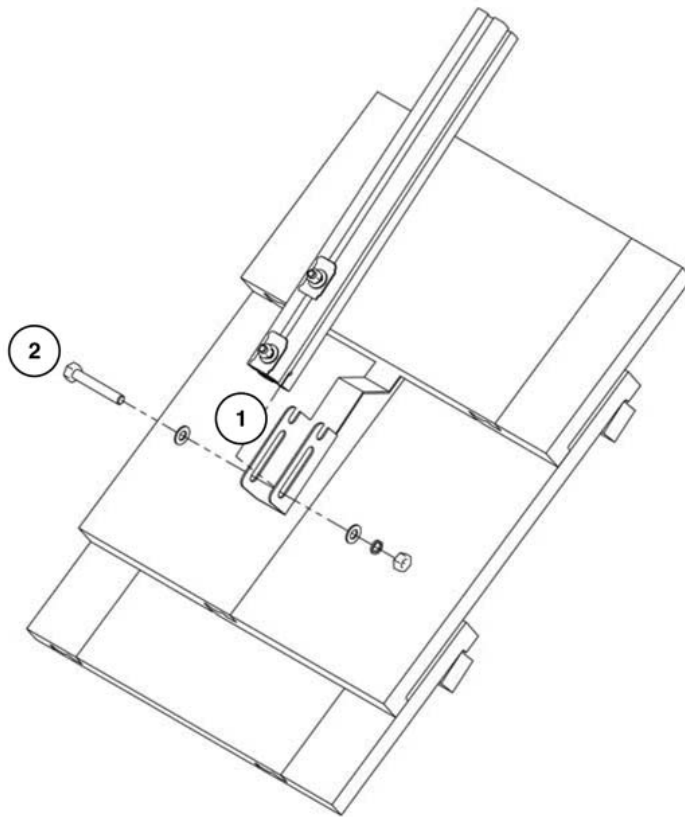

①			x1
②			x2
③	B4311, A0168, A0170, A0836		x2
④			
⑤			
⑥			
⑦			

 B1



		
①	B4331, A4305	x1
②	A2932, A2934, A2935, A2936	 20-25 Nm x1
③		
④		
⑤		
⑥		
⑦		



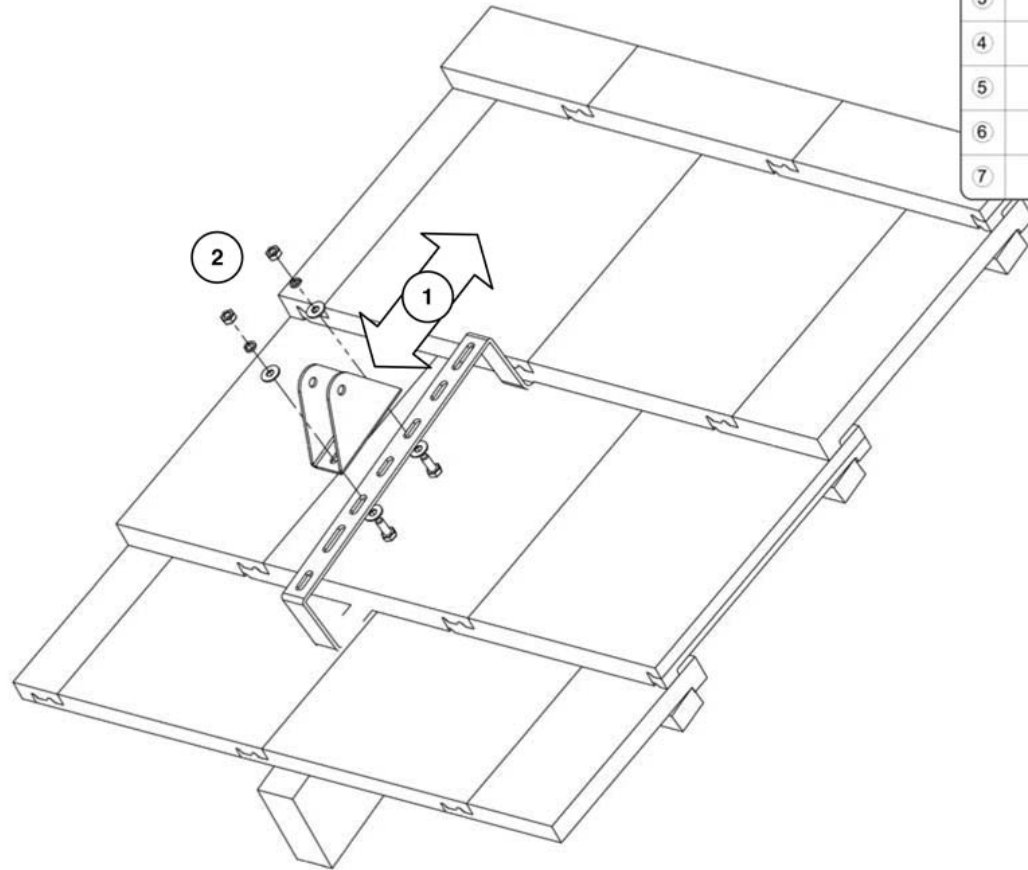

B2

Icon	Part Number	Quantity	Notes
1		x1	
2	A0249, B4311, A0169, A0175, A0170, A0172	x2	13 20-25 Nm
3			
4			
5			
6			
7			

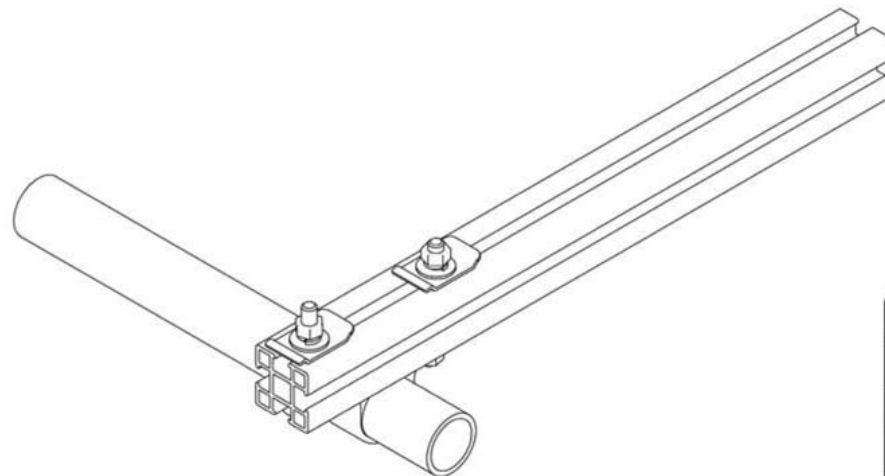
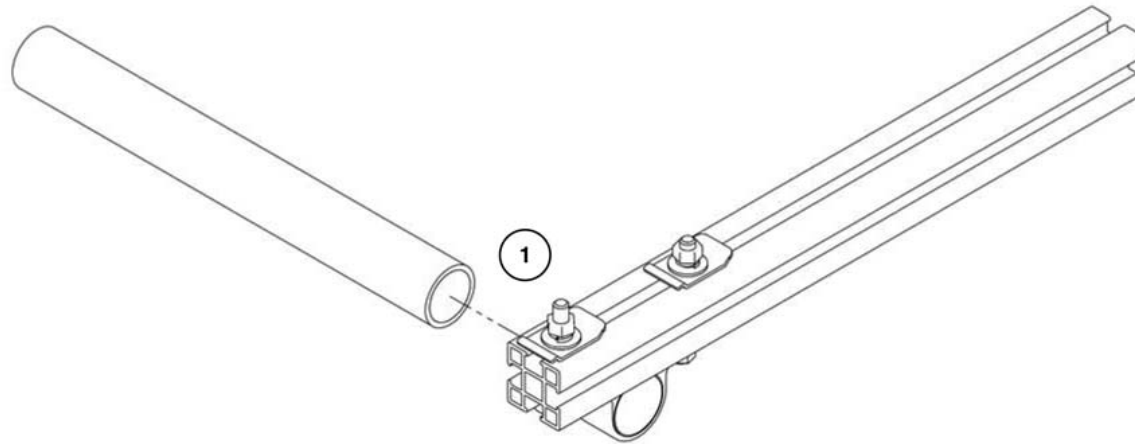

 B3



			
①	A4354	 13 20-25 Nm	x2
②			
③			
④			
⑤			
⑥			
⑦			

 B4

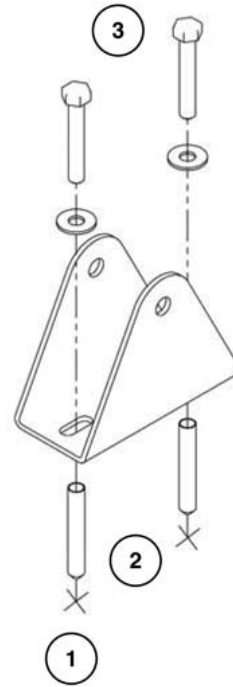

			
①		 	x1
②		 S10 	x2
③	A2937, A0168, A0170, A0836	 	x2
④			
⑤			
⑥			
⑦			

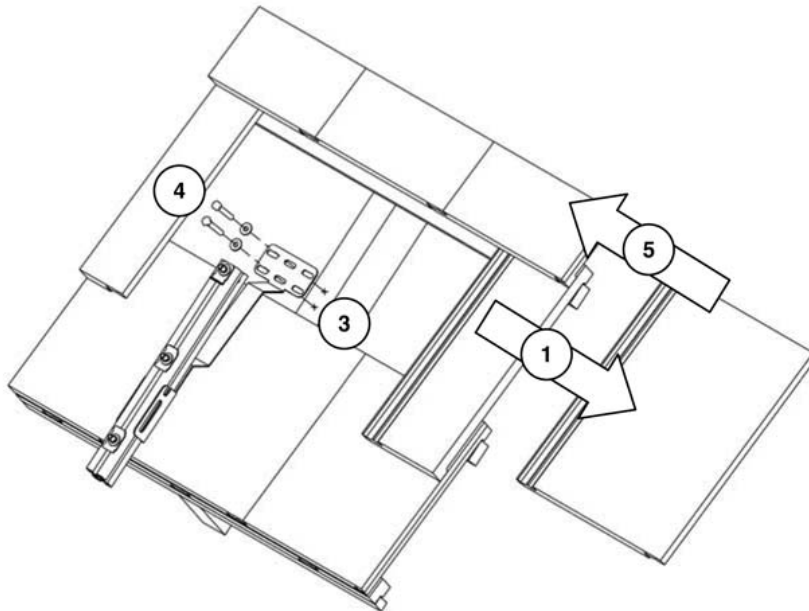

D1

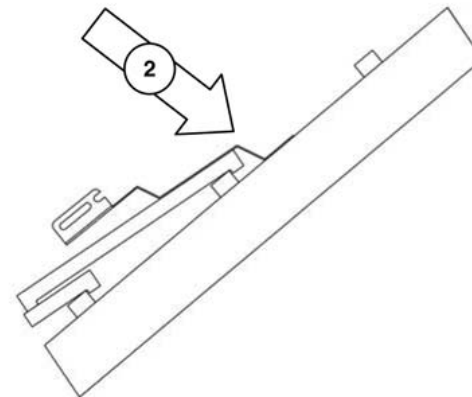

①			x1
②	B4331		x1
③			x2
④	A0168, A0170		x2
⑤			x1
⑥			
⑦			



D2

		
①	A4306/A4307 A4322/A4323 B3411	x4
②	A2932, A2934, A2935, A2936	 20-25 Nm
③		
④		
⑤		
⑥		
⑦		

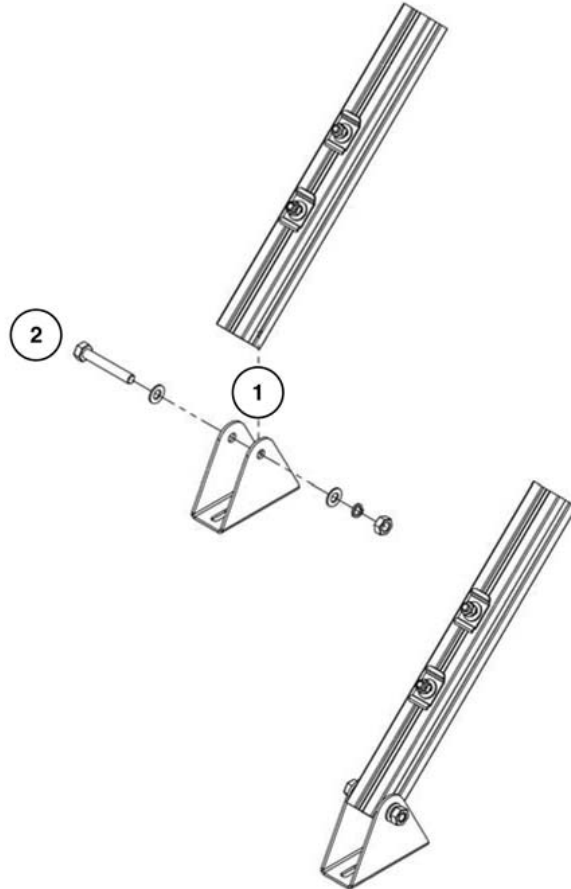

D3

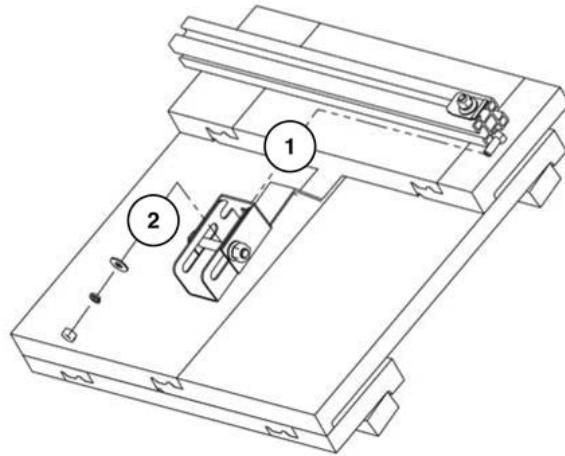

①	A4447, A4448		x2
②	A0169, A0170, A0172, A0175,	 13 20 - 25 Nm	x2
③			
④			
⑤			
⑥			
⑦			

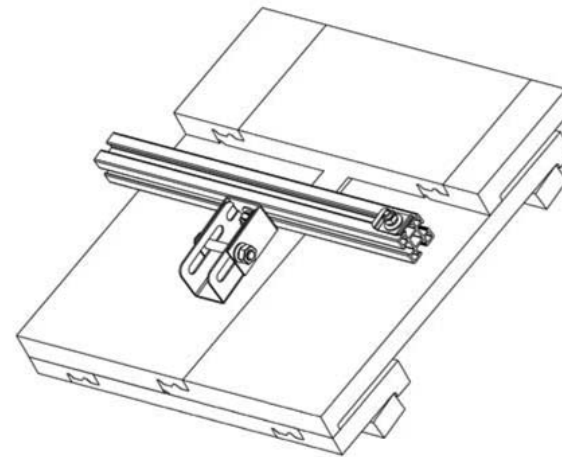

 D4

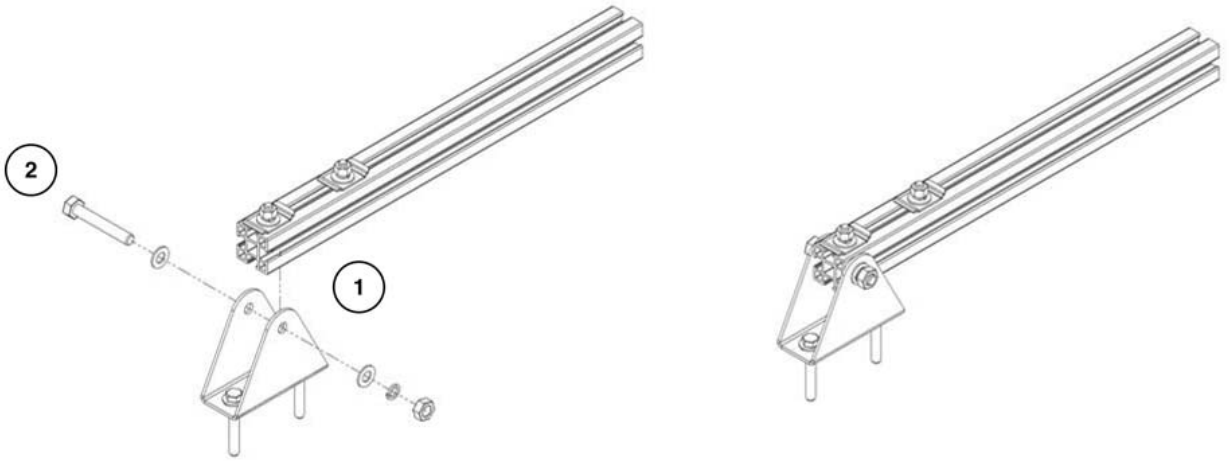

		
①	A4408 A4448 B4311	x2
②	A2932, A2934, A2935, A2936	 17 20-25 Nm x2
③		
④		
⑤		
⑥		
⑦		

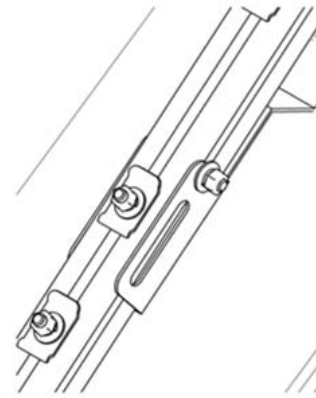
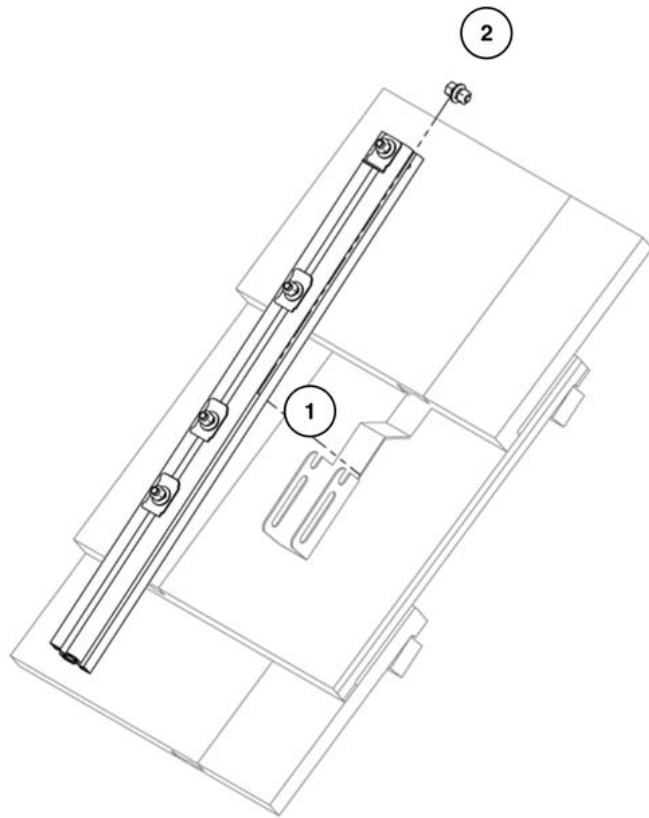

E1





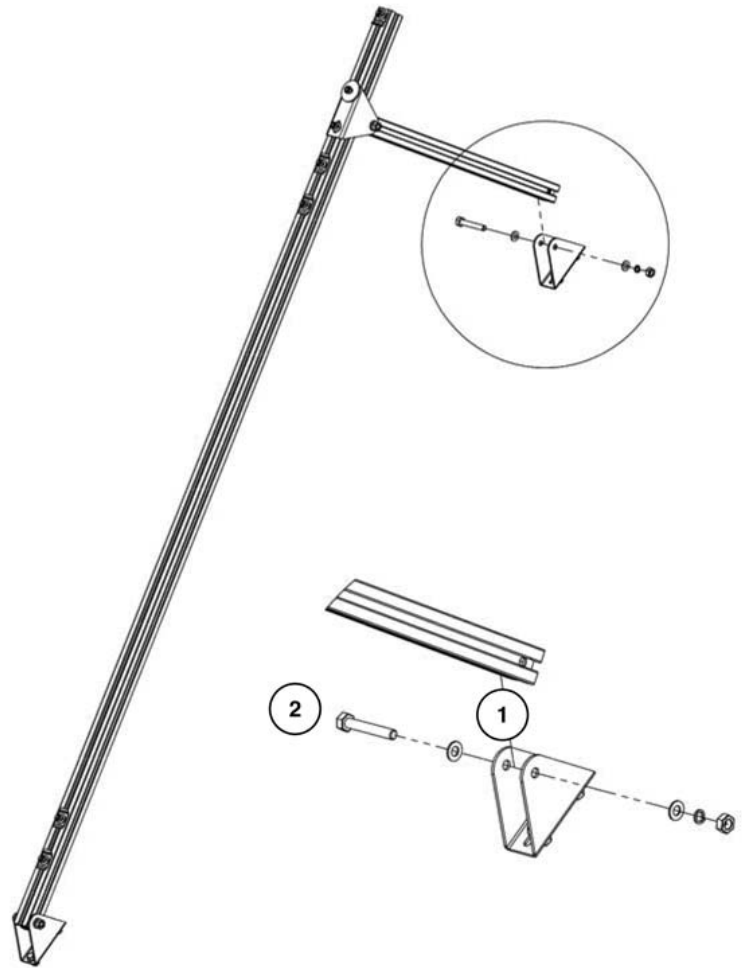

①	A4305, B4331		x2
②	A0169, A0170, A0172, A0175	 13 20-25 Nm	x2
③			
④			
⑤			
⑥			
⑦			

 E2



		
①	A4306 A4307 B4311	x2
②	A2932, A2934, A2935, A2936	 17 20-25 Nm x2
③		
④		
⑤		
⑥		
⑦		

E3

			
①	A4322 A4323	A2937	x2
②	A2932, A2934, A2935, A2936	 17 	x2 20-25 Nm
③			
④			
⑤			
⑥			
⑦			

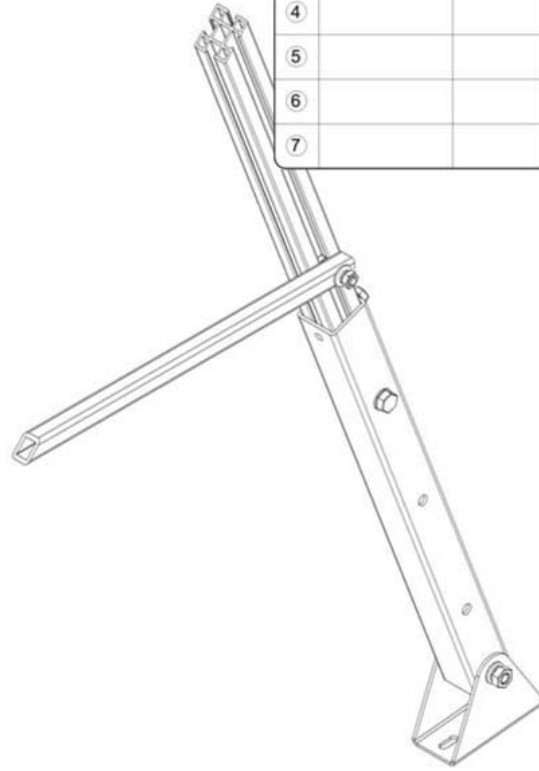
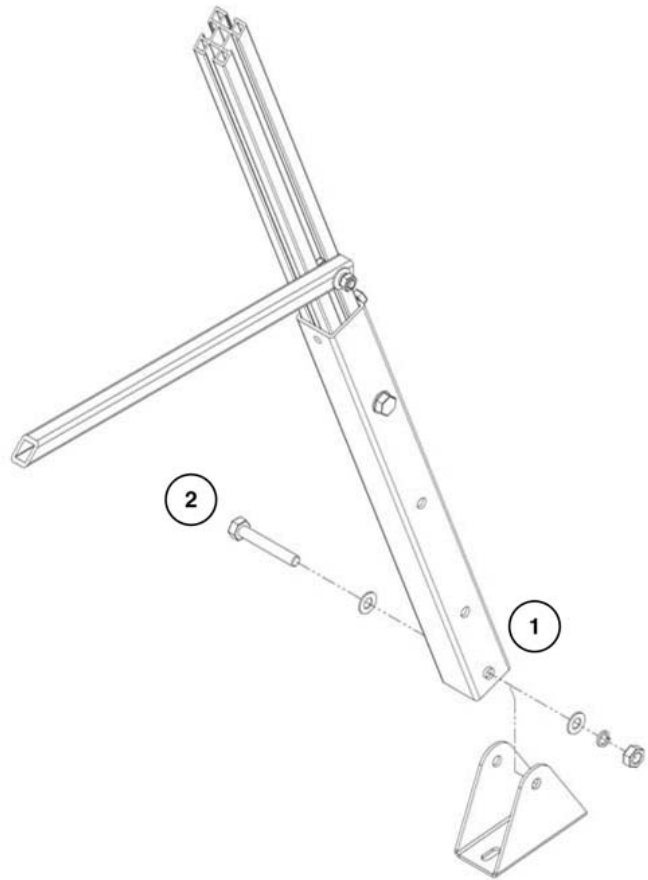

F1

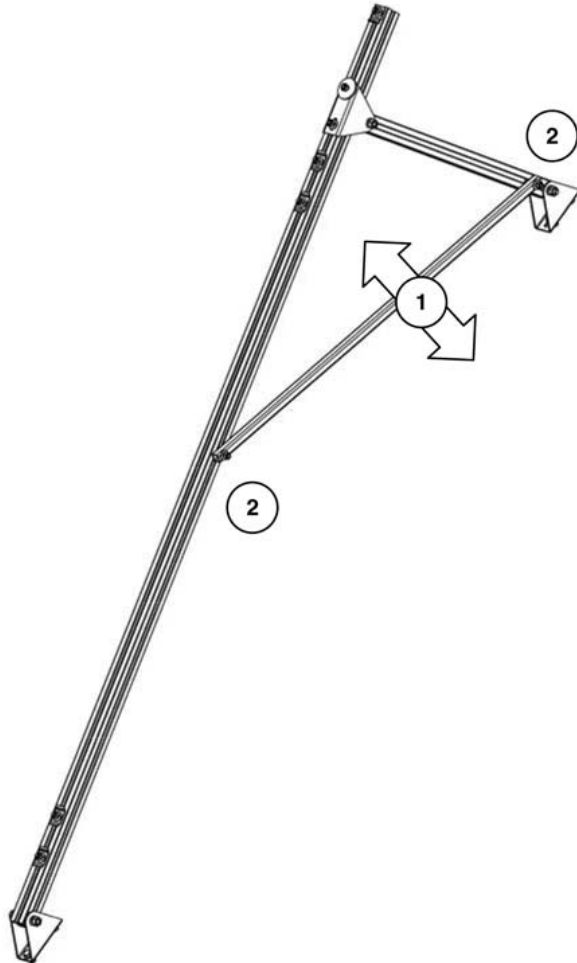

🔧	■		⚙️
①	A4306, A4307		x1
②		 15 20-25 Nm	x2
③			
④			
⑤			
⑥			
⑦			

F2

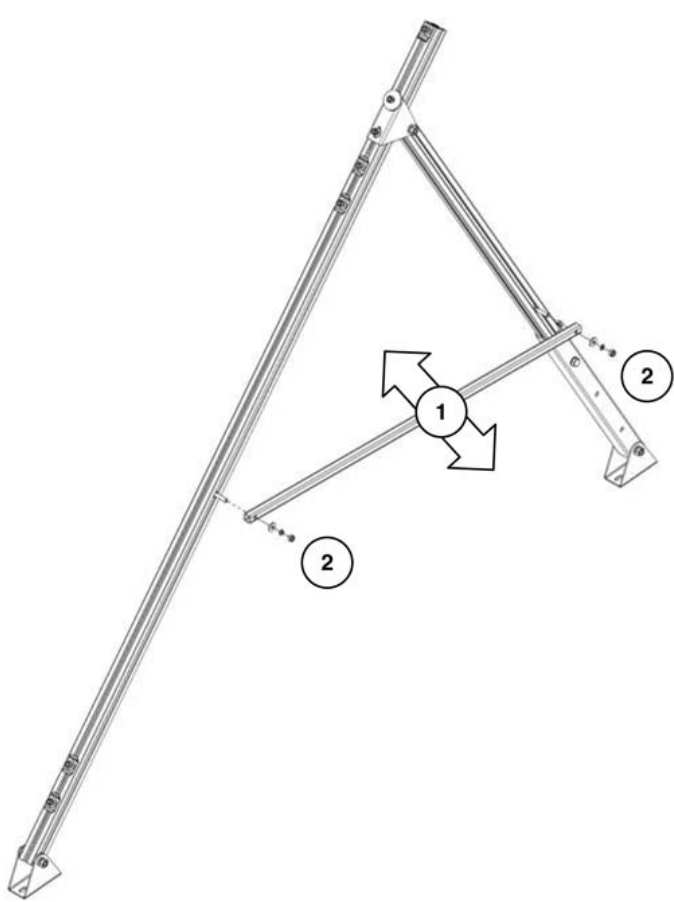

Icon	Part Number	Quantity	Notes
①	A4322, A4323	x1	
②		x2	13 20-25 Nm
③			
④			
⑤			
⑥			
⑦			

G1

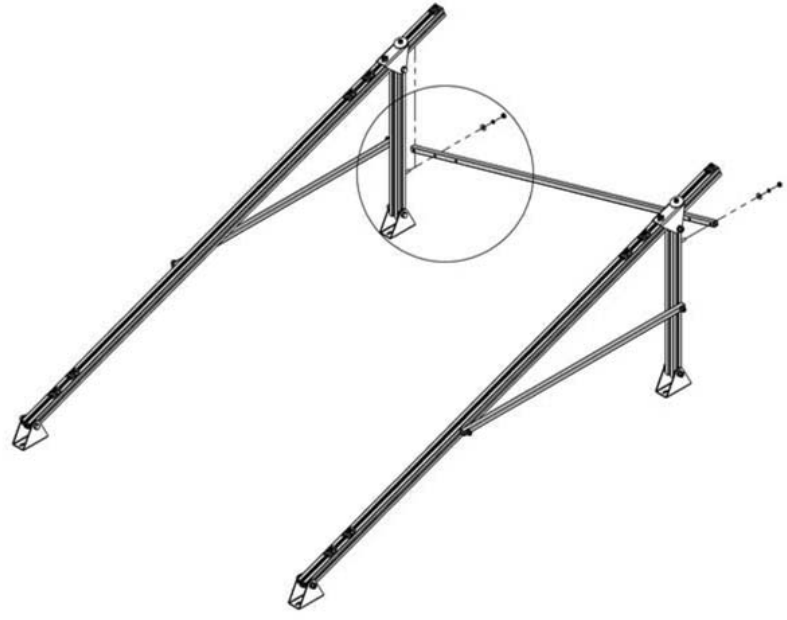

			
①	A4306 A4307	A2941	x2
②	B2948		x1
③	A0169, A0170, A0172	 20-25 Nm	x2
④			
⑤			
⑥			
⑦			

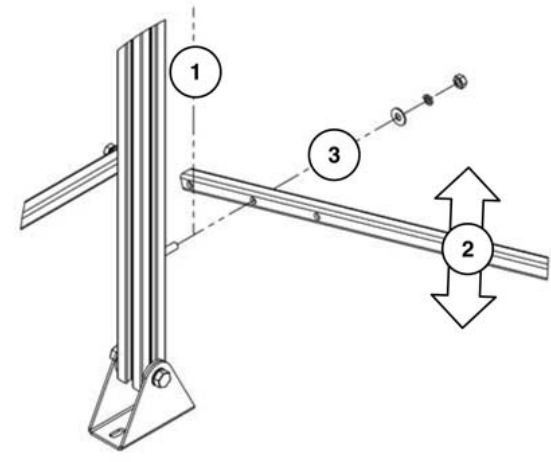

G2

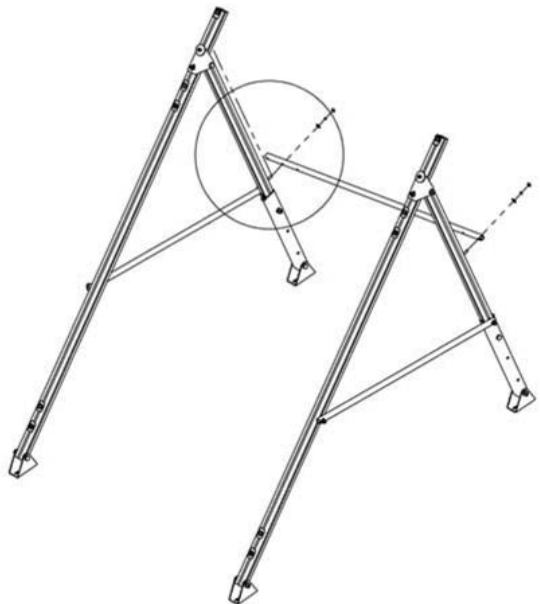

①	A4322 A4323	A2941	x2
②	B2948		x1
③	A0169, A0170, A0172	 20-25 Nm	x2
④			
⑤			
⑥			
⑦			

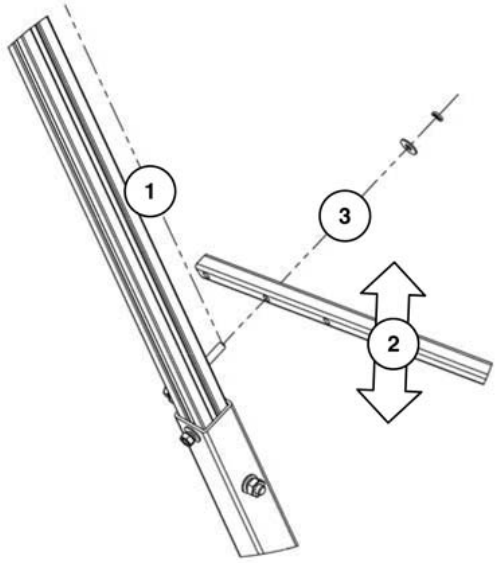

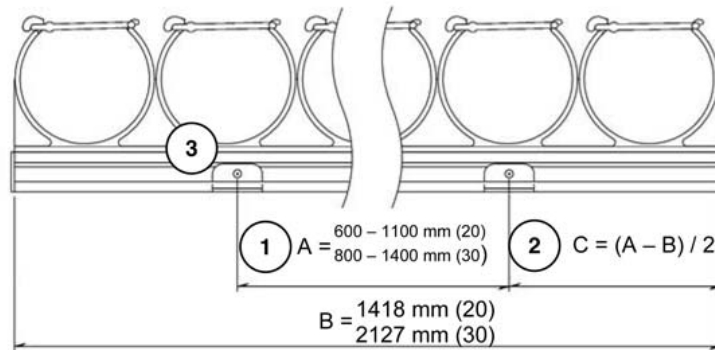
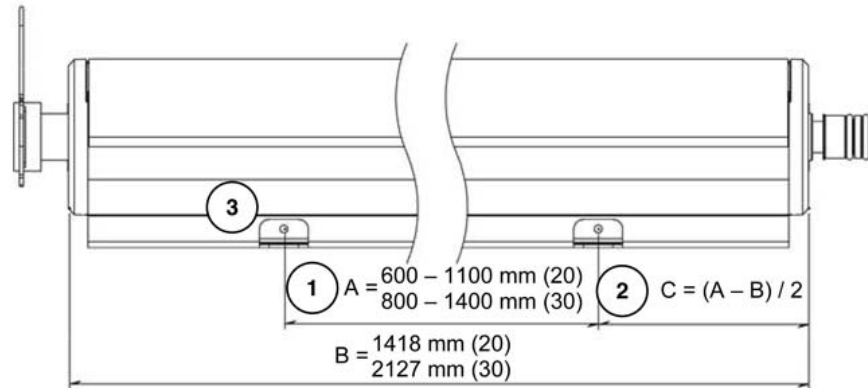

①			x1
②			x2
③			x2
④			
⑤			
⑥			
⑦			

11

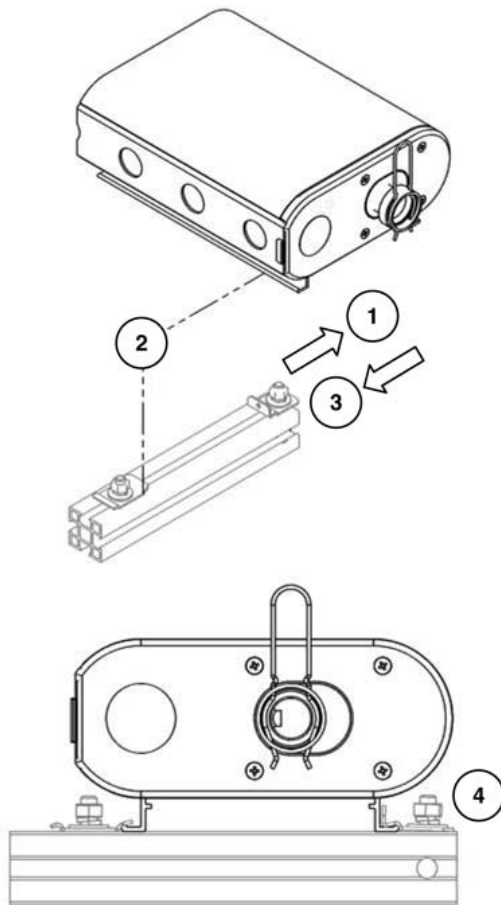

		
①	A4305 A4354 A4408	x2
②	DF 100: A2704/A2711 HP 100: A4423/A4424 HP 200: A4425/A4426	x1
③		x2
④	 20-25 Nm	x2
⑤		
⑥		
⑦		

I2

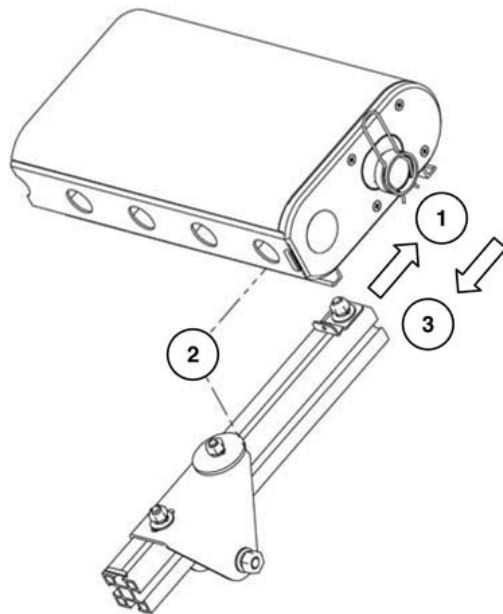

			
①	A4306/A4307 A4322/A4323		x2
②	DF 100: A2704/A2711 HP 100: A4423/A4424 HP 200: A4425/A4426		x1
③			x2
④		 13 20-25 Nm	x2
⑤			
⑥			
⑦			

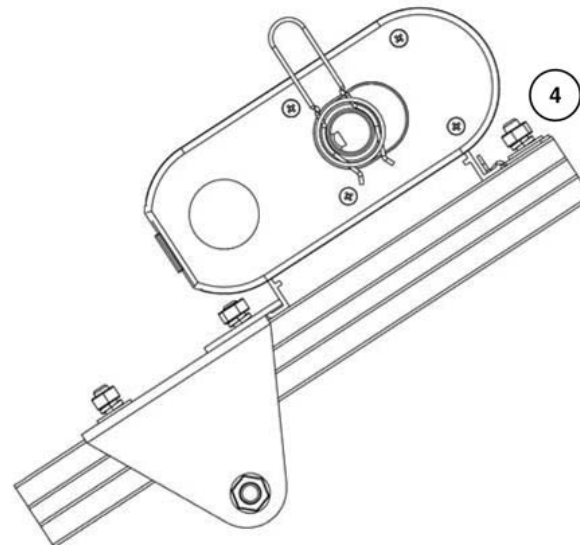

I3

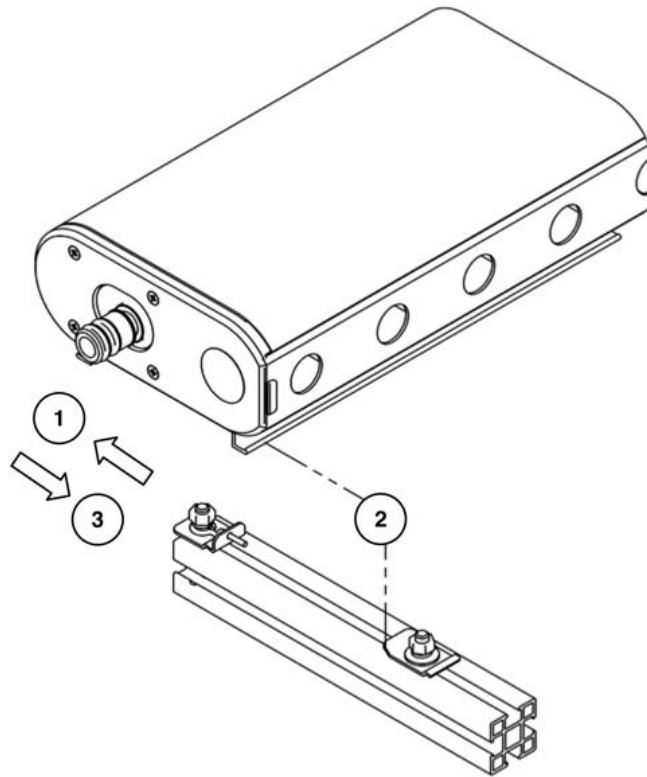

①	A4448		x2
②	DF 100: A2704/A2711 HP 100: A4423/A4424 HP 200: A4425/A4426		x1
③			x2
④		 13 20-25 Nm	x2
⑤			
⑥			
⑦			

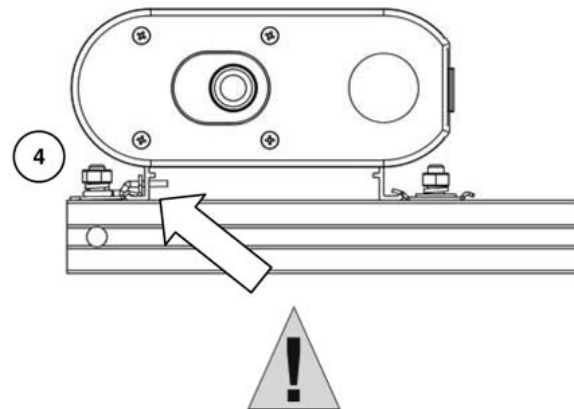

J1

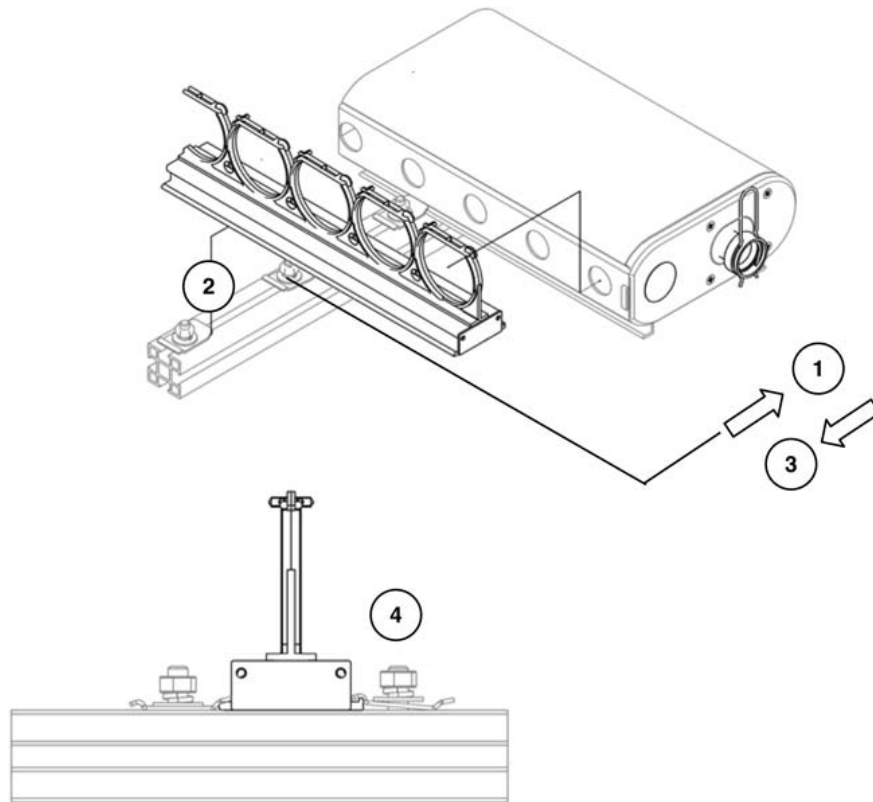

①	A4305 A4354 A4408	A4306/A4307 A4322/A4323	x2
②	A3033 (20) A3035 (30)		x1
③			x2
④		 13 20-25 Nm	x2
⑤			
⑥			
⑦			

J2

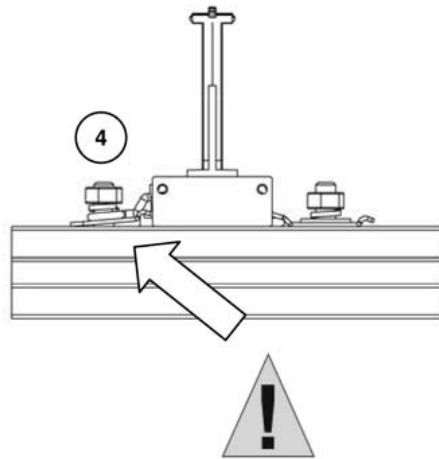
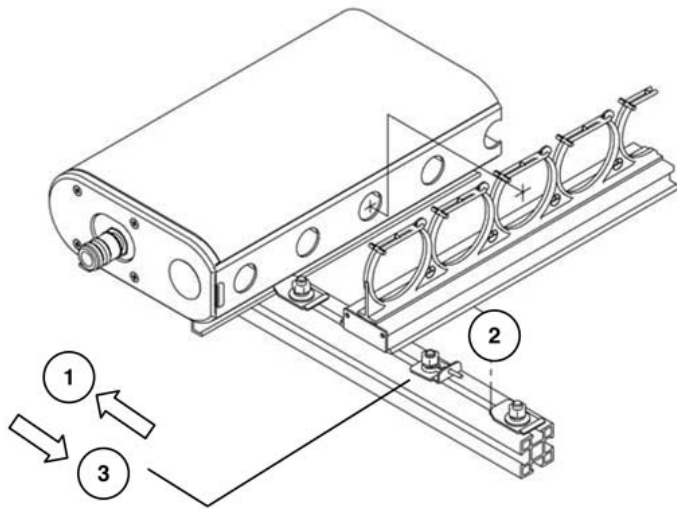

①	A4448		x2
②	A3033 (20) A3035 (30)		x1
③			x2
④		 13 20-25 Nm	x2
⑤			
⑥			
⑦			

4 Installation of Accessory Kits



4.1 Connection Kit

- 1 Tighten compression fitting to connection fitting (flow and return)
- 2 Tighten compression fitting to pipe work (flow and return)
- 3 Attach assembled fittings to manifold
- 4 Push clip all the way down until connection is fully retained
- 5 Pull gently on assembly to ensure proper engagement and retention

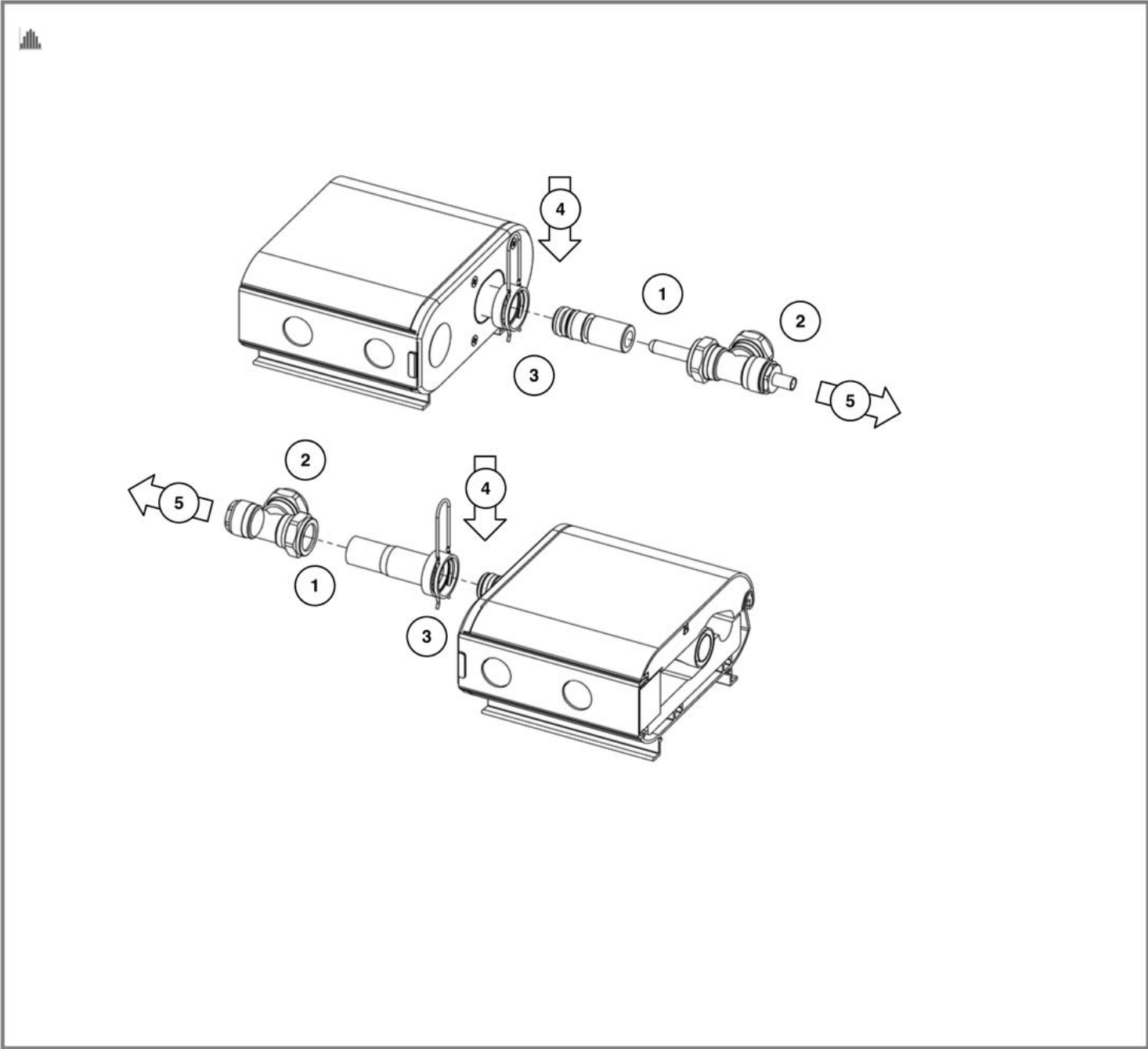

4.2 Interconnection Kit

- 1 Insert screws into plate ensuring screws do not protrude to upper side
- 2 Slide plate approximately half way into channel at bottom of manifold that is fixed to side rails
- 3 Tighten up screws to force plate against bottom of manifold (do not overtighten)
- 4 Slide channel of next manifold on plate
- 5 Push clip all the way down until connection is fully retained
- 6 Assemble support rail connection plate to fixed support rails
- 7 Assemble retaining plates and fittings

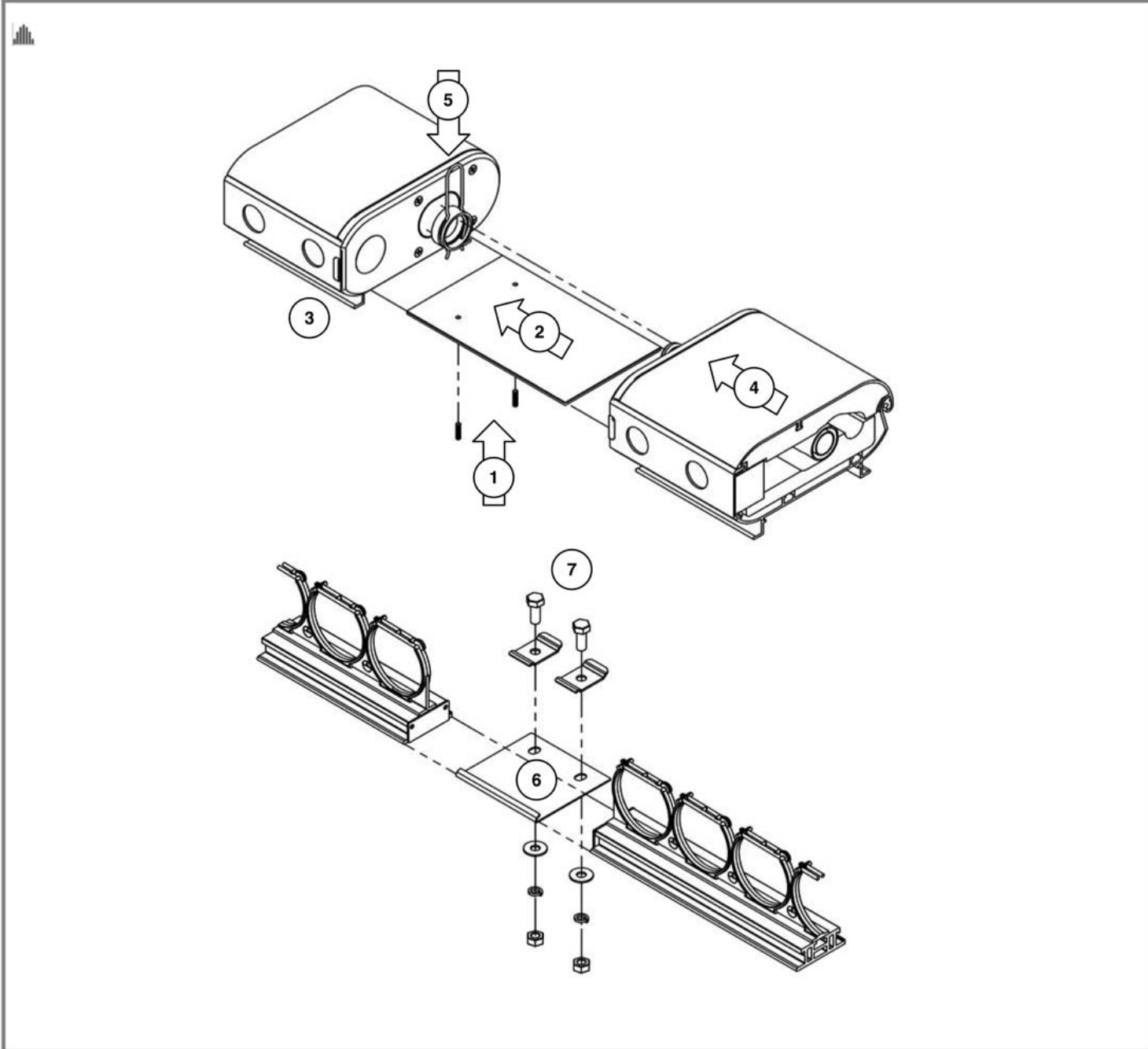

4.3 Air Separator Kit

- 1 Tighten connection fitting to air-separator
 - 2 Tighten air separator to pipe work using straight connector
Do not apply force on o-ring connection to manifold when tightening air separator!
 - 3 Ensure air separator is up-right
- ⚠ If slope $>45^\circ$ air separator to be installed horizontally or in parallel with manifold axis.

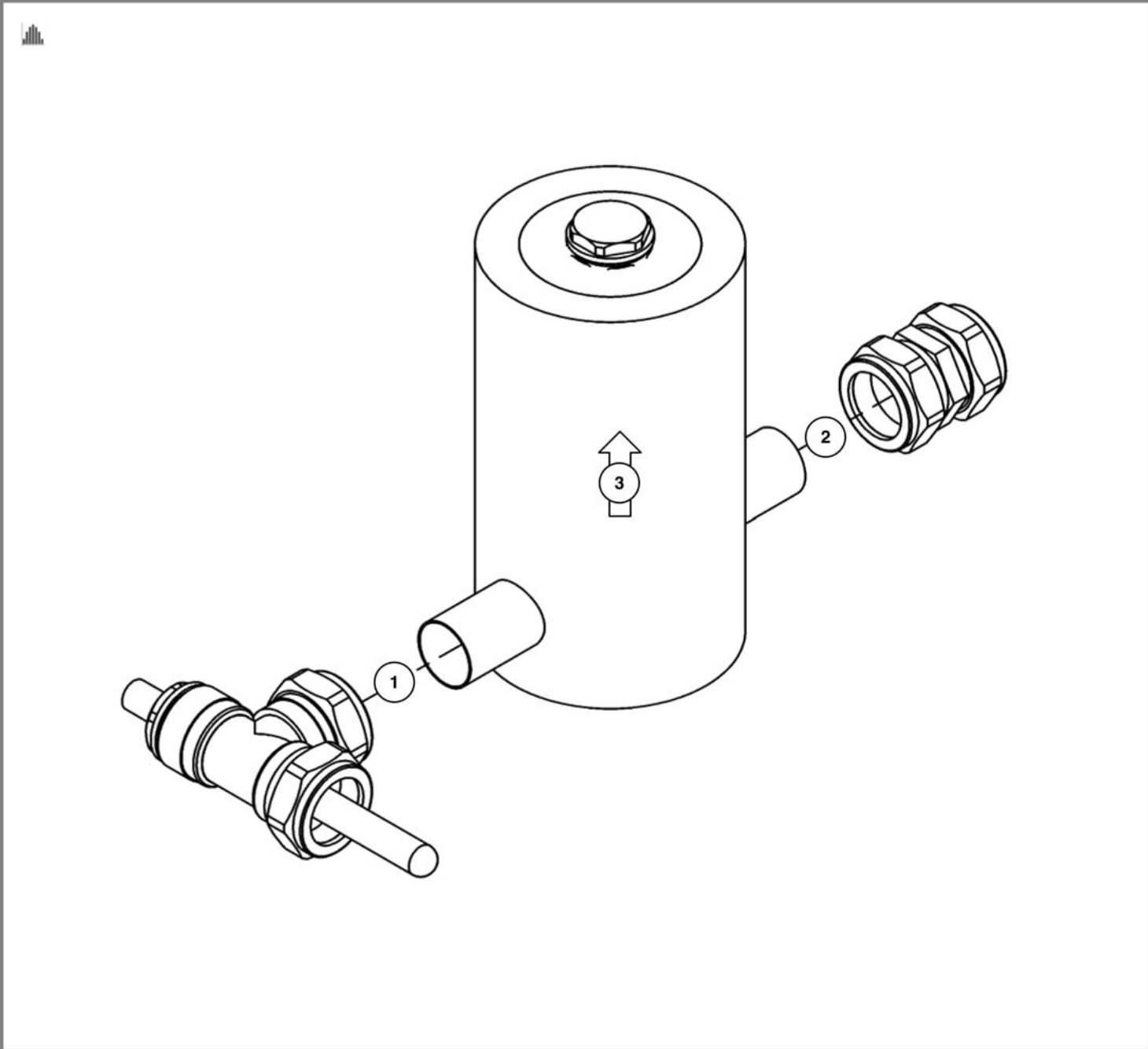

5 Installation of Tubes



5.1

- 1 Open manifold lid by removing front seal strip as shown on manifold end cap
- 2 Place tube in tube clips on both support rails
- 3 Slide tube into manifold connection while slightly rotating tube until washer on bellow sits flush against manifold fitting. Do not apply force, if any problems check alignment of support rails to manifold.
- 4 Insert tube retaining clip to secure tube to manifold.
- 5 Gently pull on tube to ensure secure assembly.
- 6 Close tube retaining rubber on both support rails. Repeat steps 2 to 6 for all tubes.
- 7 Close manifold lid ensuring proper engagement of front seal strip over whole length and on end caps.

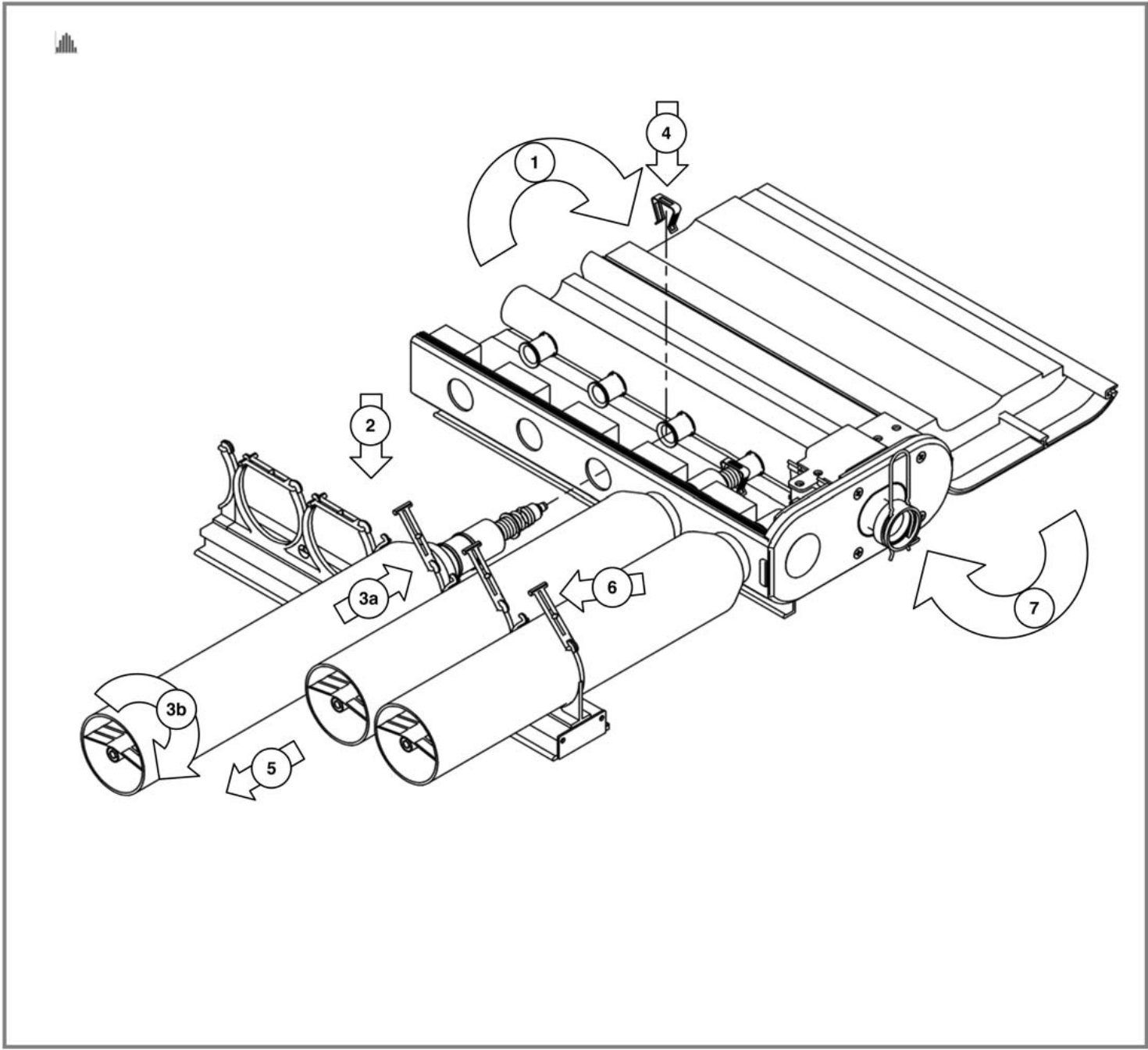

PART OF BDR THERMEA

Baxi Commercial Division
Wood Lane, Erdington,
Birmingham B24 9QP
Email: andrews@baxigroup.com
www.andrewswaterheaters.co.uk

Sales:
0845 070 1056
Technical:
0845 070 1057

