

B185 CORREX POWERED ANODE KIT

Fitting Instructions

ST Range Water Storage Vessels



THE INTRODUCTION OF THIS KIT HAS THREE MAIN ADVANTAGES TO BE CONSIDERED:

- Low Maintenance Costs (Correx is non-sacrificial, therefore no anode maintenance is needed)
- Low Running Costs (Less than 35kWH per year)
- Increased protection (particularly in areas of low electrical conductivity).

Mains electrical supply wiring to the water heater must be installed in accordance with the current Building Regulations in force and BS7671 - Requirements for Electrical Installations.

This kit is designed to use a 220/240V 1ph 50Hz permanent supply. The fuse rating is 3 Amp.

The method of connection to the mains electrical supply should facilitate complete electrical isolation of the Correx kit and the appliance. The point of connection to the mains should be readily accessible and adjacent to the appliance.

Step 1 To install the Correx kit (refer to Fig1 diagram)

1. Drain down the water heater.
1. Remove the existing magnesium anode(s).
1. Fit the correx anode(s) into the connection(s).
1. Fix the potentiostat to the heater casing using the retaining bracket provided.
1. Connect the potentiostat output lead onto the anode connection(s). Achieve this by cutting the lead to the desired length and using the crimp type female connector provided.
1. Remove one heater top cover retaining screw and connect the earth return at this point by cutting the lead to the desired length and using the crimp type spade connector provided.
1. Connect the potentiostat mains cable to a permanent 220/240V 1ph 50Hz electrical supply via an unswitched spur outlet (fuse rating 3A).

Step 2 Test the installation

1. Refill the water heater and check for leaks.
2. Switch on the electrical supply to the potentiostat.
3. The green lamp on the potentiostat indicates that the installation is functioning correctly.
4. The red lamp on the potentiostat indicates a fault. Switch off the electrical supply before any work is carried out.

The installation is now complete.

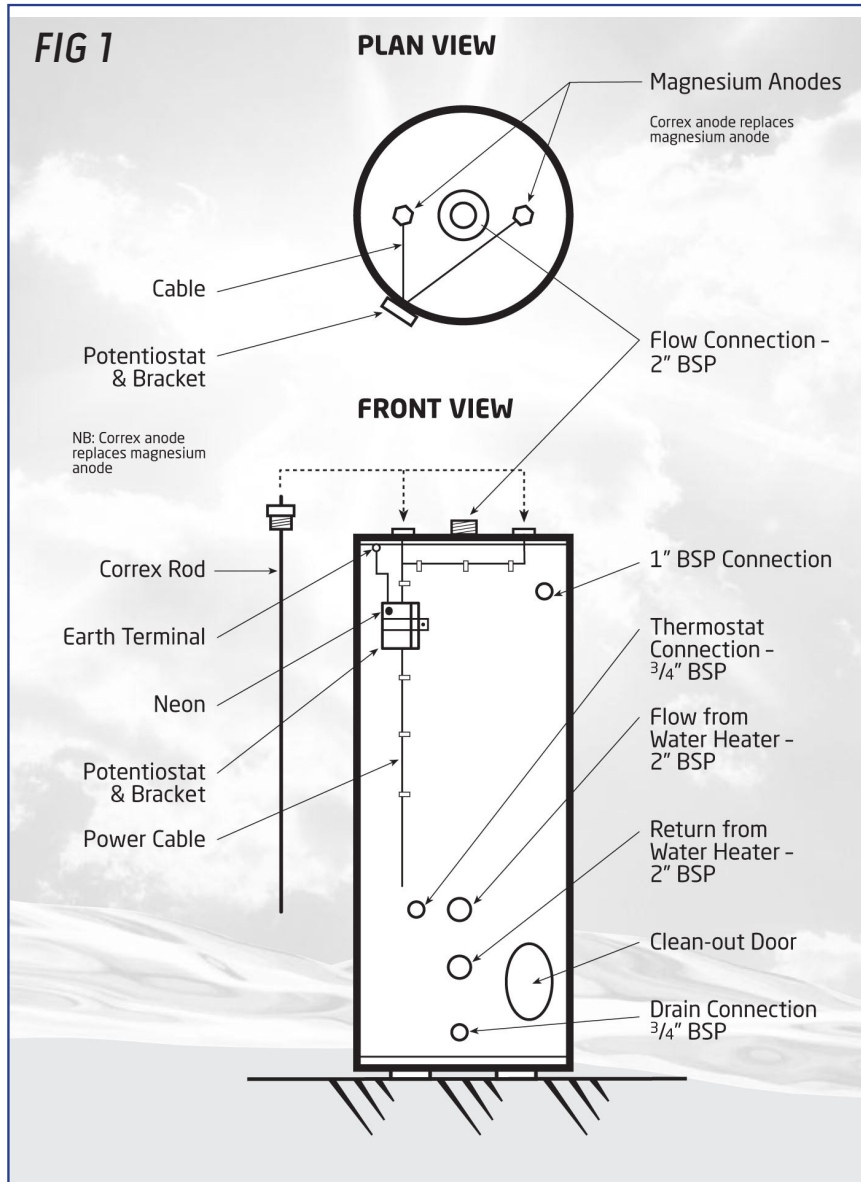

| Model | Qty of original fitted anodes | Qty & Size of Correx Anodes |
|--------|-------------------------------|-----------------------------|
| ST 66 | 2 | 2 x 800mm |
| ST 100 | 2 | 2 x 800mm |
| ST 166 | 2 | 2 x 800mm |

| B185 – Anode Fitting Pack Contents | |
|------------------------------------|------------------------------|
| Qty | Part |
| 1 | E048 – Correx Powered Anodes |
| 1 | E010 – Potentiostat |
| 1 | E049 – Earth Strap |

November 2016

Customer support
Monday - Friday
8am - 5pm

Sales
0345 070 1055
Technical
0345 070 1057
Website
andrewswaterheaters.co.uk
Twitter
@AndrewsWH



RS 33961

