

T/D 029

FITTING INSTRUCTIONS FOR FLUE DAMPER KIT

6" Part No. B146 (32/143) – 6" Part No. B202 (65/173, 81/264)
8" Part No. B147 (62/341) – 10" Part No. B148 (54/440)

‘E’ SERIES, AUTO-IGNITION MODELS, NATURAL GAS

The introduction of a flue damper will, on stand-by, reduce stored water heat losses due to the reduction of natural thermal currents through the heat exchanger and flue system.

A. To install the kit

1. Move the ON/OFF switch located on the auto ignition panel to OFF and isolate the unit from the electrical supply.
2. Move the gas control knob to OFF.
3. Remove the draught diverter and make sure the metal flue spigot from the primary flue outlet has been removed. (For 54/440 fit flue spigot E044 supplied by Andrews Water Heaters). (See Fig. 1).
4. Offer the flue damper assembly to the flue outlet keeping the drive unit in vertical alignment with the control thermostat. (See Fig. 2).
5. Using the damper assembly as a template, carefully drill 4 off 3mm holes through the pre-punched holes of the damper channel. Fix using the 4 self-tapping screws provided. For B148 (54/440) use bracket provided in damper kit. (See Fig. 2).
6. Wire flying lead supplied into terminal locations in the auto ignition kit. (See wiring diagram Fig. 3).
7. Connect flying leads together ensuring correct colour sequence is observed. (See Fig. 2).
8. Move flue damper link to ON position. (See wiring diagram Fig. 3).
9. Ensure that the flue damper drive unit switch is in the auto position. (See Fig. 2).
10. Re-fit the draught diverter.

B. Test the installation. Do not turn on gas.

Upon completion of all installation work, the damper operation should be checked prior to commissioning as follows:

1. Move the thermostat to its desired setting.
2. Move the ON/OFF switch to ON.
3. After a delay of several seconds, the flue damper will open and the heater ignition system will make an ignition attempt.
4. Move the ON/OFF switch to OFF, at which point the flue damper will close.

The unit should now be fully commissioned after which, shut down of the thermostat will cause the flue damper to close on stand-by.

Fig. 1

Remove the metal flue spigot from the primary flue outlet.

For model 54/440 only, fit the flue spigot supplied in the damper kit by Andrews Water Heaters.

Part No. E044.

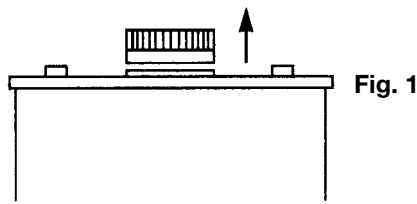

Fig. 2

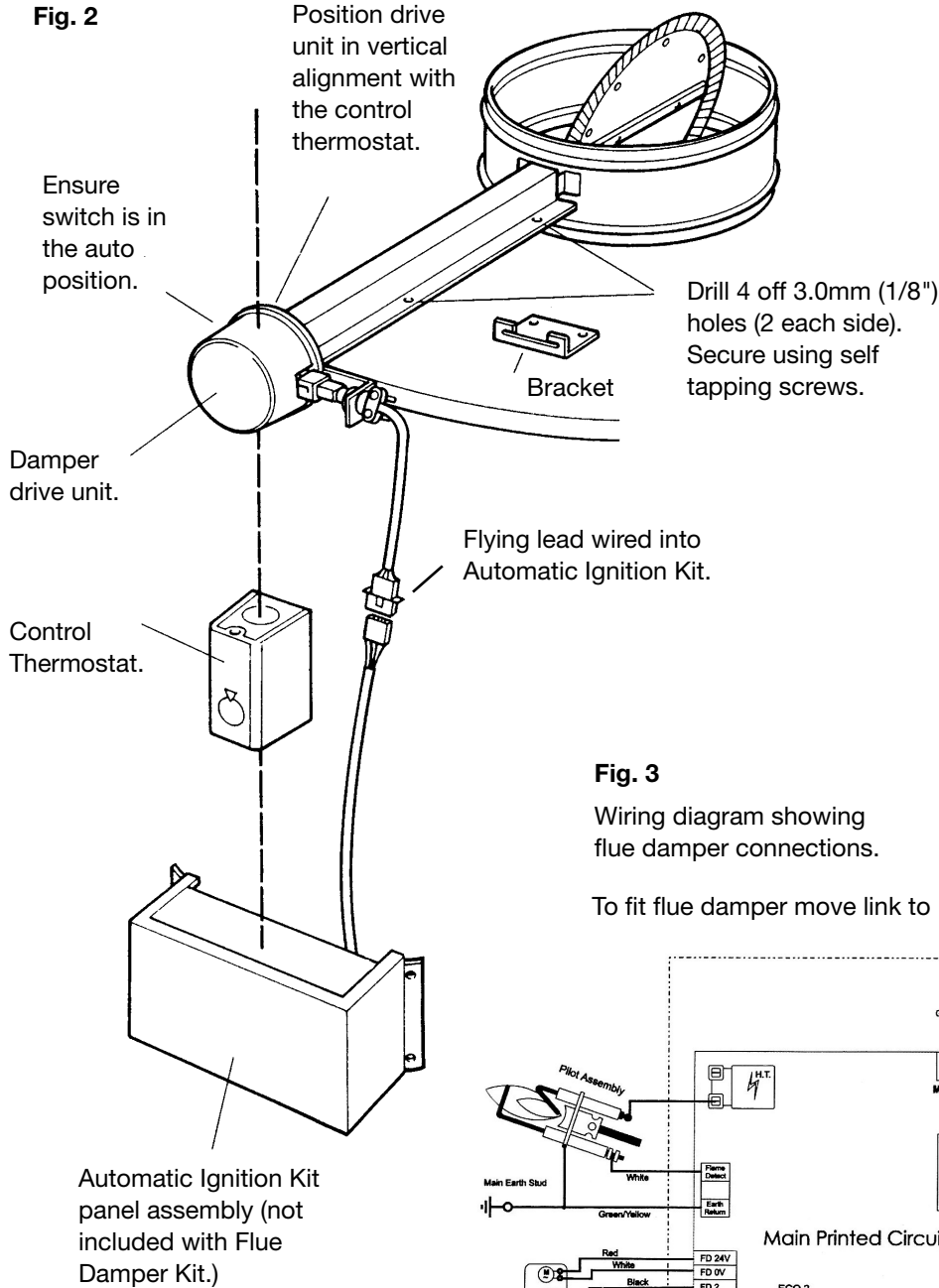

Fig. 3

Wiring diagram showing flue damper connections.

To fit flue damper move link to 'ON' position and wire as shown.

