



MAXXflo EVO Technical Specification Guide

Andrews. Built to perform.

CONTENTS

Welcome to Andrews Water Heaters	03
Introducing the MAXXflo EVO	04
Water heater construction	05
Technical information	06
MAXXflo EVO suggested engineer specification	07
Dimensions and connections	08
Wiring information	09
Typical flue installation	10
Complete unvented systems kit and accessories	11
Technical support and declaration of compliance	12
Size-it information	13
Range overview	14

For further information on the MAXXflo EVO and other Andrews Water Heaters products, contact your Area Sales Manager today. Details can be found at andrewswaterheaters.co.uk

WELCOME TO ANDREWS WATER HEATERS

Andrews Water Heaters is the market leading manufacturer of commercial gas fired water heaters.

Established in 1976, Andrews has a comprehensive range, meaning we have the solution for any commercial and industrial application, however large or small.

Our water heaters are energy efficient and fully compliant with water byelaws, Part L of the Building Regulations, and the Low Carbon Buildings Programme.

With a specialist team, and a reputation for quality, reliability and high performance products, Andrews can provide hot water delivery to meet the requirements of the most demanding applications.

Introducing the MAXXflo EVO

We've re-engineered MAXXflo to create MAXXflo EVO. Specifically designed to meet industry demands – it delivers low, future-proofed NO_x emissions that meet the London Plan. With efficiency of up to 98%, new BMS connectivity offering 24/7 remote monitoring and a continuous supply of hot water with a 1920lt/hr recovery rate it delivers class-leading performance.

Models available in 30, 60, 90 and 120kW outputs with 200 or 300 litre storage capacity.

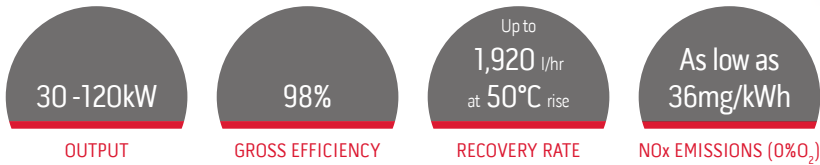

Features

Benefit

30 and 60kW single burners and twin burners between 90 and 120kW	With fewer burners both commissioning and planned maintenance costs are minimised
Independent service valves and pressure sensors on each heat exchanger in twin burner versions	Full built in redundancy and service flexibility as burners and heat exchangers can be isolated for servicing
Low NO _x burners	Compliant with and exceeds current legislative requirements
High efficiency modulating pumps (ErP rated A)	Improved operating efficiencies with greater temperature control
Multi-line graphical display	Access to live data, settings and history. Easy to use with full control of the burners and accurate charging of integral tank
Ready to connect into BMS via Modbus protocol	Easy integration into Building Management System for remote monitoring and control; identifies specific problems and maximises maintenance efficiency
Full anti-legionella functions with strap-on sensor as standard	Control of secondary return circuit temperature and pump operation ensures protection against legionella and improves safety

Water heater construction

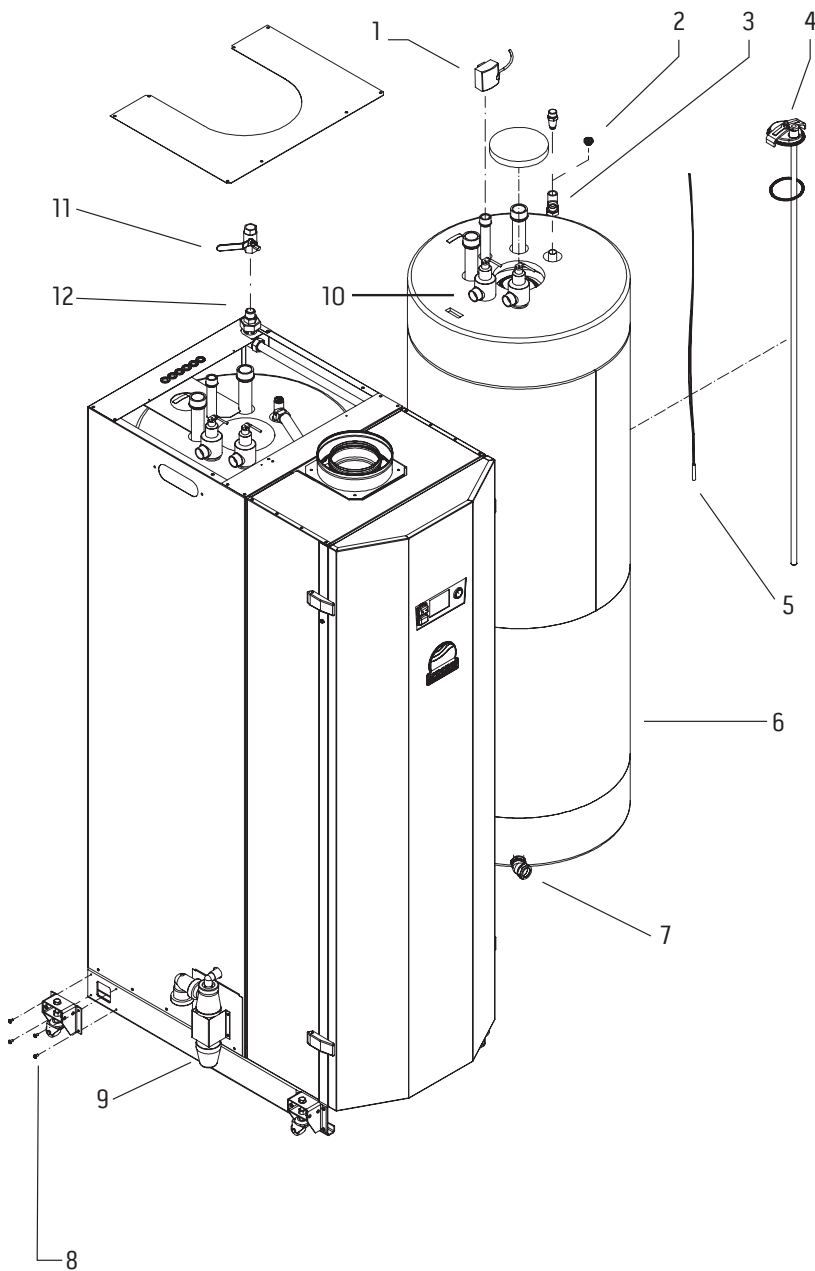

- | | |
|----|--|
| 1 | Return Sensor Kit |
| 2 | Air vent 1/2" |
| 3 | 28x28x1/2" Compression Tee |
| 4 | Access Hatch Assy inc. o-ring |
| 5 | Temp Sensor DHW Tank B3 |
| 6 | Tank |
| 7 | 28mm Obtuse Compression Elbow |
| 8 | Option - Castor Assembly |
| 9 | Condensate Trap |
| 10 | Temperature/Pressure Relief Valve 10bar/95°C |
| 11 | 3/4" Gas Cock c/w test nipple |
| 12 | 3/4" Gas Union M&F |

Technical information

		SINGLE BURNER				TWIN BURNER	
		CWH 30/201	CWH 30/301	CWH 60/201	CWH 60/301	CWH 90/302	CWH 120/302
Product code		7726948	7726950	7726949	7726951	7726952	7726953
Performance	Maximum heat input net (gross)	kW	28(31)	28(31)	56(62)	56(62)	84 (93) 112 (124)
	Heat output	kW	30.5	30.5	61	61	91.6 122
	Gross thermal efficiency	%	98	98	98	98	98% 98%
	Standby loss	kWh/day	1.68	2.26	1.68	2.26	2.26 2.26
ErP	NO _x emissions (0% O ₂)	mg/kWh	39	39	36	36	39 36
	ErP efficiency rating		A	A	A	A	- -
	Water heater efficiency	%	95	98	91	97	91 90
	Noise level (EN15036-1 avg @1m)	dba	53	63	53	63	62 65
Gas data	Gas flow rate (natural gas)	m ³ /hr	2.95	2.95	5.95	5.95	8.7 11.6
	Gas flow rate (propane)	m ³ /hr	1.15	1.15	2.35	2.35	3.5 4.7
Water	Storage capacity	litre	200	300	200	300	300 300
	Recovery rate through 50°C Δt	litre/hr	480	480	960	960	1440 1920
	Recovery rate through 56°C Δt	litre/hr	429	429	856	856	1286 1712
	Maximum operating pressure (unvented)	bar	6	6	6	6	6 6
	Minimum working pressure	bar	0.8	0.8	0.8	0.8	0.8 0.8
	Maximum static pressure	bar	7.5	7.5	7.5	7.5	7.5 7.5
Electrical	Fuse rating	amp	5	5	5	5	5 5
	Power consumption - standby	W	3.5	3.5	3.5	3.5	5.5 5.5
	Power consumption - max	W	100	100	145	145	210 290
	Electrical requirements	V	220 - 240 @ 50Hz				220 - 240 @ 50Hz
Misc	Weight full	kg	370	485	380	490	485 505
	Weight empty	kg	155	165	170	180	185 205
	Maximum outlet temperature	°C	65	65	65	65	65 65
	Maximum flue gas temperature	°C	90	90	90	90	90 90
Connection sizes and Dimensions	Inlet/outlet connections	BSP	1½"	1½"	1½"	1½"	1½" 1½"
	Return connection	BSP	1"	1"	1"	1"	1" 1"
	Gas connection	BSP	¾"	¾"	¾"	¾"	¾" ¾"
	Water heater height	mm	1556	1980	1556	1980	1980 1980
	Diameter of water heater	mm	602	602	602	602	602 602
	Water heater depth	mm	1046	1046	1046	1046	1046 1046
	Flue diameter - conventional flue	mm	80	80	80	80	130 130
	Flue diameter - concentric balanced flue	mm	80/125	80/125	80/125	80/125	130/200 130/200
Service clearance	Front	mm	800	800	800	800	800 800
	Right side	mm	200	200	200	200	200 200
	Rear	mm	200	200	200	200	200 200
	Left side	mm	300	300	300	300	300 300
	Above	mm	300	300	300	300	300 300
Shipping	Shipping width	mm	880	880	880	880	880 880
	Shipping depth	mm	1160	1160	1160	1160	1160 1160
	Shipping height	mm	2213	2213	2213	2213	2213 2213
	Shipping weight	kg	224	239	234	239	254 274

MAXXflo EVO comes with one factory fitted T&P valve in the single burner models and two T&P valves in the twin.

MAXXflo EVO suggested engineer specification

The MAXXflo EVO is a high efficiency fully condensing floor standing storage water heater incorporating multiple heat exchanger modules*.

Each independent tube heat exchanger module shall be located on the side of the storage vessel, be constructed from grade 316L stainless steel. The integral storage tank shall be constructed from grade 316L stainless steel and both shall be connected with 22mm and 28mm interconnecting copper pipework.

The storage vessel shall be insulated with carbon impregnated polystyrene having a standby heat loss value from 1.68kWh/day, incorporate an inspection hatch located on the top of the vessel and have a painted steel outer casing.

The water heater shall be ErP compliant and incorporate a 10-bar / 95°C Temperature and Pressure relief valve; a condensate trap and be manufactured under the ISO 9001 quality system.

HYDRAULIC, GAS AND FLUE CONNECTIONS

The water heater shall be designed for boosted, direct mains and open vented water systems. It shall be suitable for operating on systems up to a maximum pressure of 6 bar (unvented systems).

The hot water outlet, cold water supply, secondary return and gas connections shall be ¾" BSP and shall be located on the top of the water heater. An inspection manifold shall also be provided and located on the top of the water heater.

The water heaters shall be suitable for Natural Gas or LPG.

The water heater shall be suitable for either Conventional flued installation and have either an 80mm or 130mm flue outlet diameter (model dependant) or Concentric balanced flued installation and have either an 80 / 125mm or 130 / 200mm flue outlet diameter (model dependant).

OPERATION

Each MAXXflo EVO incorporates pre mix fully modulating gas burner module/s* with electronic ignition and ionisation control. Each burner shall provide modulation from 100% to 10%, efficiencies of 98% (Gross CV) and NO_x emissions of 39 mg/kWh or lower.

Each heat exchanger module also has its own high efficiency fully modulating A rated pump and an integral flue non return valve.

As standard the MAXXflo EVO Siemens controls provides a detailed graphical interface giving access to live data, settings and history. Also, full control of the burner(s) with accurate charging of the integral tank and control/monitoring of auxiliary pump(s) and tank(s). The in-built anti legionella facility includes control of secondary return circuit temperature and pump operation (pump not included). Times can be set via the integral time clock.

The control panel display indicates operating water temperature and lockout status.

ELECTRICAL CONTROLS

The unit shall be supplied as standard with the following controls:

- Full PID modulation controls
- Modbus BMS connectivity
- Status outputs for run and fault indication via V.F.C
- Enable – V.F enable input
- Volt free contact
- Anti-Legionella function complete with secondary return temperature
- Full control of secondary return pump

Each MAXXflo EVO shall be CE and GAR approved for UK and IE. WRAS is pending.

*90 and 120kW models

Dimensions and connections

		SINGLE BURNER				TWIN BURNER	
		CWH 30/201	CWH 60/201	CWH 30/301	CWH 60/301	CWH 90/302	CWH 120/302
A: Inlet/outlet connections	BSP	1½	1½	1½	1½	1½	1½
B: Return connection	BSP	1	1	1	1	1	1
C: Gas connection	BSP	¾	¾	¾	¾	¾	¾
D: Water heater height	mm	1556	1556	1980	1980	1980	1980
E: Width of water heater	mm	602	602	602	602	602	602
F: Water heater depth	BSP	1046	1046	1046	1046	1046	1046
G: Flue diameter - connection balanced flue	mm	80/125	80/125	80/125	80/125	130/200	130/200

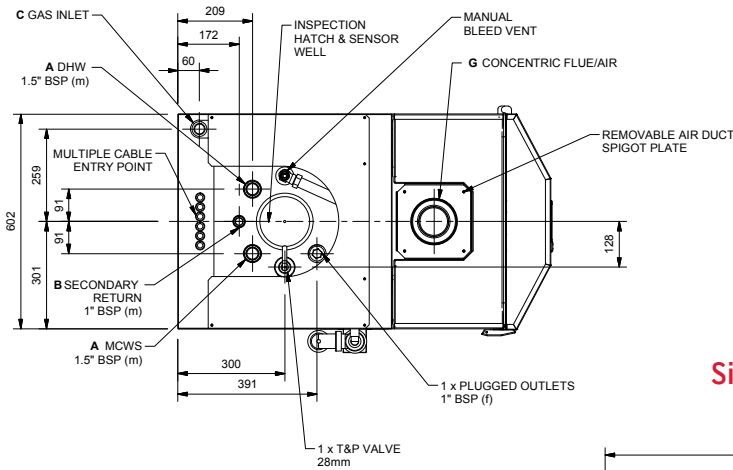

Side view

Front view

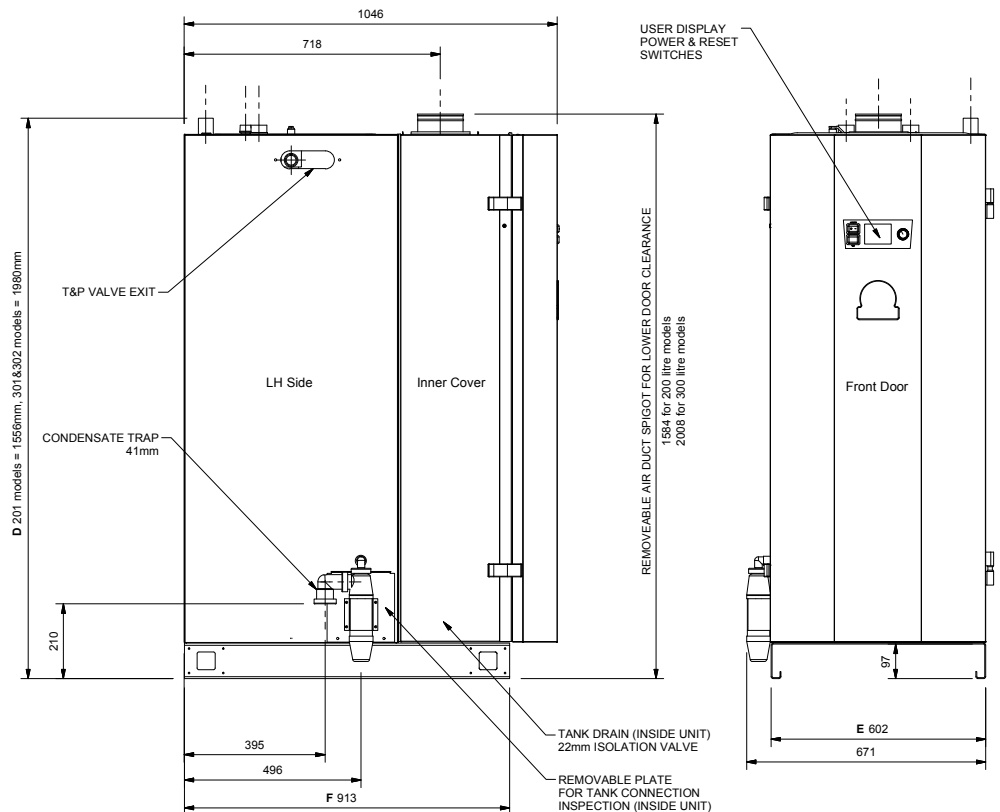

Wiring information

WIRING DIAGRAM FOR MAXXflo EVO c/w ADDITIONAL STORAGE TANKS

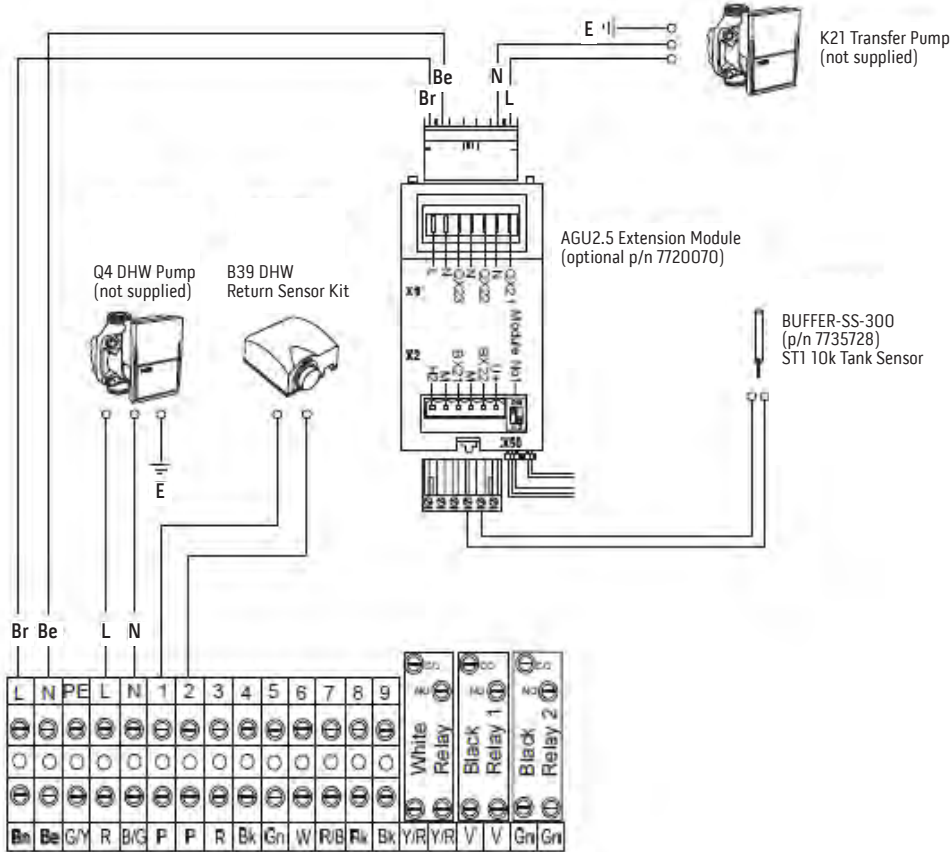

STANDARD BMS CONNECTIONS

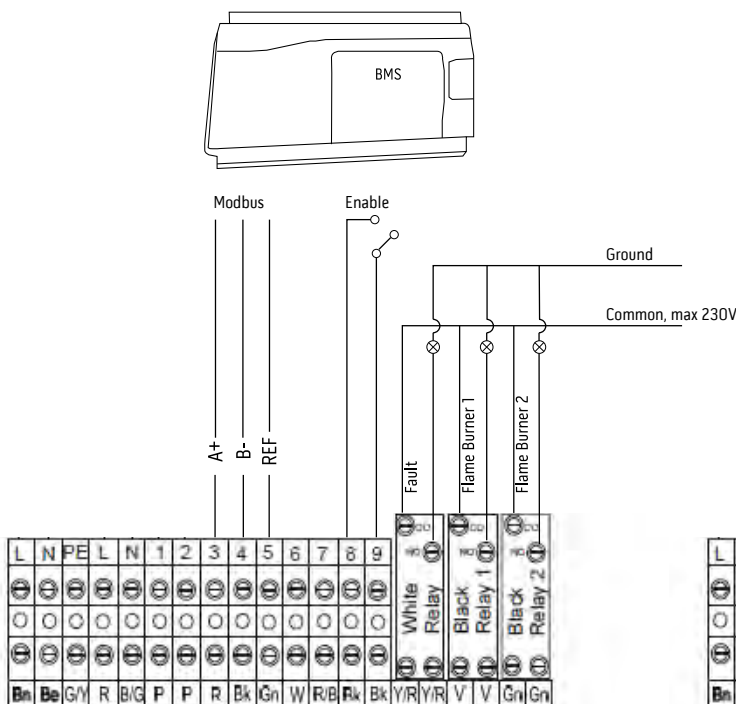

STANDARD WIRING FOR SECONDARY RETURN PUMP

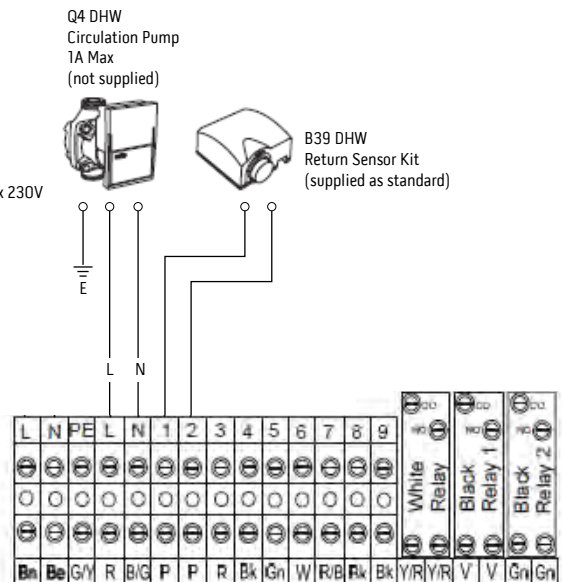

Typical flue installation

The route of the flue is critical when planning horizontal runs, potential condensate traps must be avoided. When calculating maximum flue runs, a reduction must be made of one metre run per 90° elbow and a half metre run per 45° elbow.

Concentric maximum equivalent flue length
 30 & 60kW = 18 meters (C13, C33)
 90 & 120kW = 24 meters (C13, C33)

The siting of the flue terminal is critical with respect to the performance of the unit. Areas where the discharge of combustion products would cause a nuisance should be avoided.

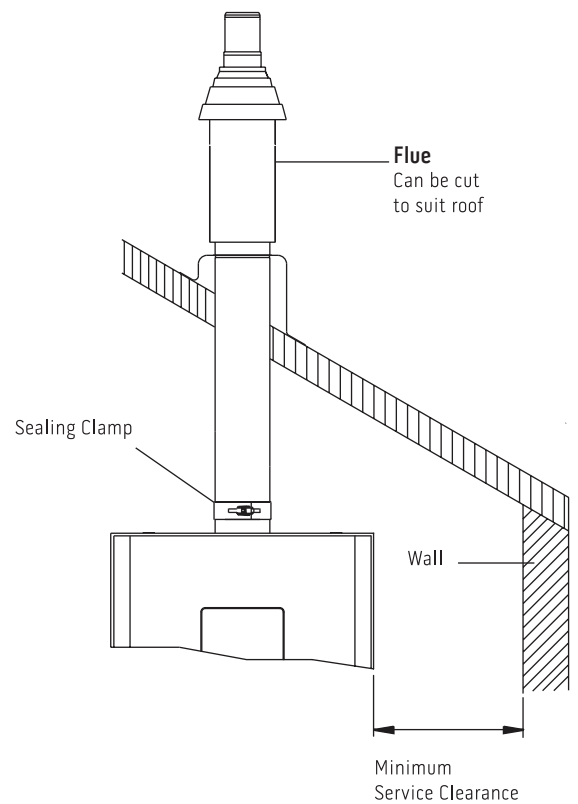
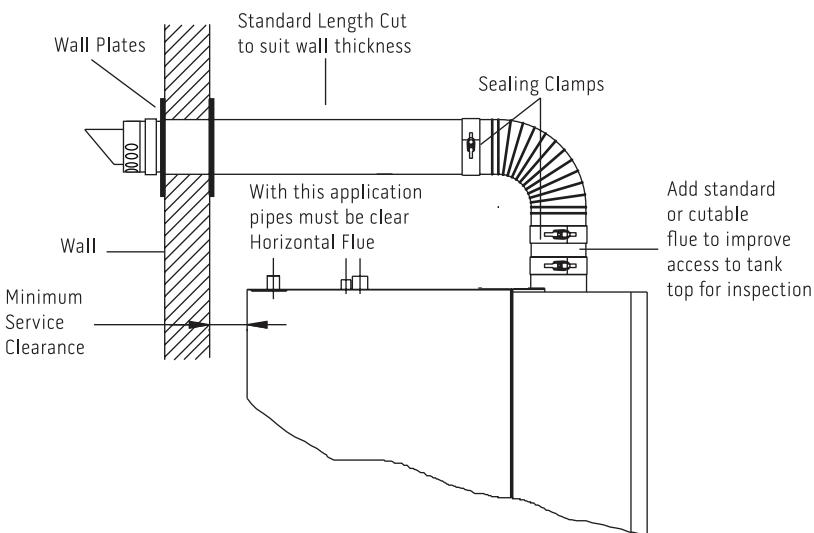

Model

	30/201	30/301	60/201	60/301	90/302	120/302
Flues						
Horizontal flue kit		7726957				7620230*
Vertical flue kit		5103917				7620229
1m cuttable flue extension		5136148				7726994
90° elbow		5136151				7620232
45° elbow		5136150				7726992
Flat roof plate		E065				E217
Angled roof plate		E066				E218
Wall bracket		5136152				E219
Wall guard		E105				E630
Flue condensate trap		7726982				7620233
Condense bottle trap		E211				E211
Condense trap pipe kit		E261				E261

*there are no elbows included in kit 7620230

Complete unvented systems kit and accessories

Ref	Description	Sales code
	Complete unvented kit	7726954
B1	One piece inlet control (pressure reducing valve 6bar, check valve, pressure relief valve 8bar)	7727950
B2	Expansion vessel (24 litre) c/w bracket	7727951
B3	Temperature/pressure relief valve 10bar/95°C (factory fitted)	7727952
B4	Tundish (supplied with the water heater)	7705047
B5	Flow through valve	7727953

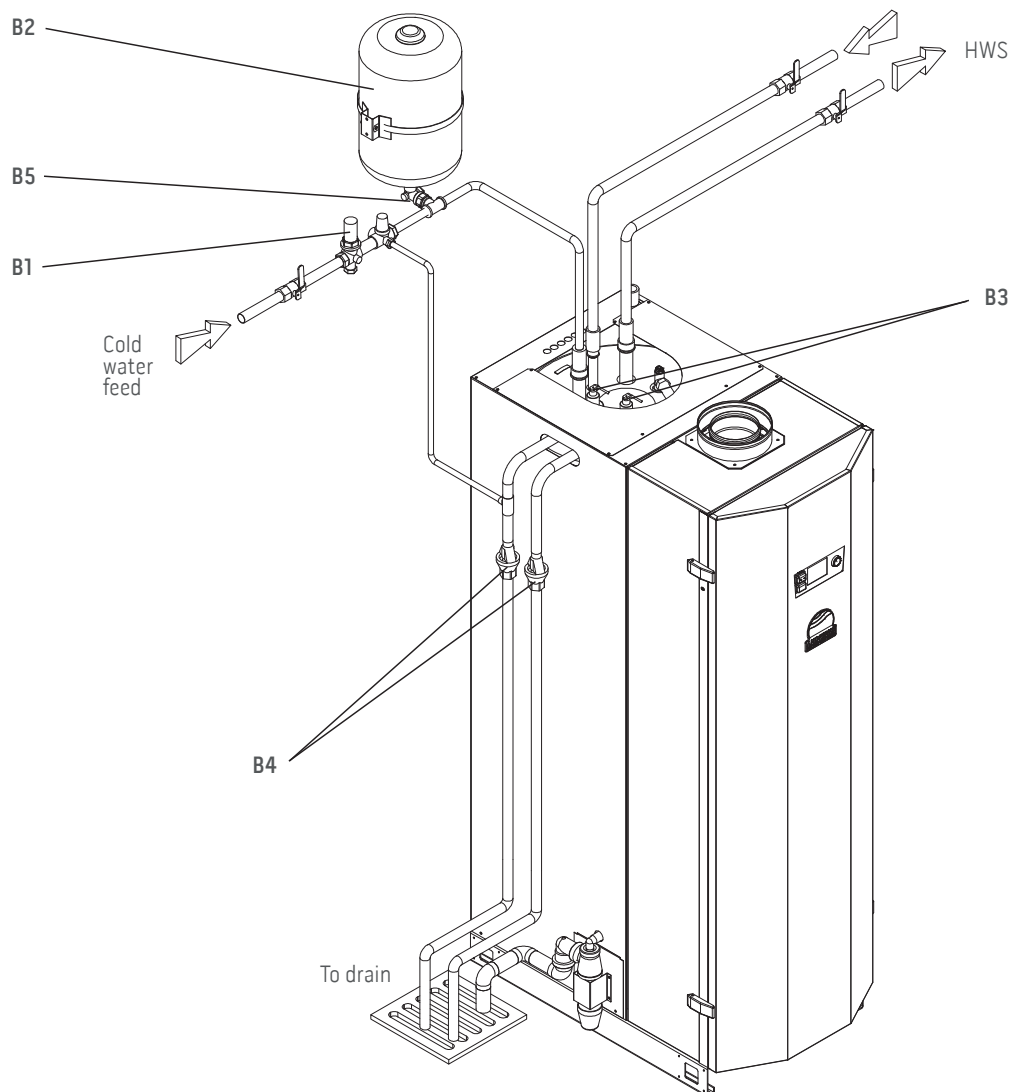

Accessories

Accessories	Sales code
6 bar unvented system kit c/w flow through valve	7726954
Set of 4 castors	7709385
Clip in expansion module	7720070
BUFFER-SS300-10, 300 litre stainless steel tank	7735728

Technical support and declaration of compliance

From brochures to CAD drawings and BIM files, you can access all the information you need at andrewswaterheaters.co.uk.

Or call our sales or technical departments on 0345 070 1057.

We can provide you with:

- Brochures
- Technical sheets
- Case studies
- Installation manuals
- CAD and BIM files
- Size-It www.sizeit.co.uk
- Energy-related Products directive data
- Commissioning
- Technical Information
- Free training courses and CPDs available www.andrewswaterheaters.co.uk/training
- 24/7 Out of Hours Engineer Support

24/7 OUT-OF-HOURS ENGINEER SUPPORT

In an emergency, we offer
technical advice

0345 070 1058

The water heater must be installed in accordance with the following regulations:

BS 6700: Specification for design, installation, testing and maintenance of services supplying water for domestic use within buildings and their curtilages. This standard supersedes the following British Standards and Codes of Practice: CP99, CP310, CP324, 202, CP342 Part 2, Centralised Hot Water Supply.

BS 5440: Installation of flues and ventilation for gas appliances of rated output not exceeding 60kW.

Part 1: Specification for installation of flues.

Part 2: Specification for installation of ventilation for gas appliances.

BS 5546: Installation of gas hot water supplies for domestic purposes.

BS 6891: Installation of low pressure gas pipework of up to 28mm in domestic premises.

BS 7206: Specification for unvented hot water storage units and packages.

BS EN 806: (Parts 1 - 5) Specifications for installations inside buildings conveying water for human consumption.

BS 6644 Installation of gas fired water boilers of rated inputs between 70kW and 1.8MW. BS EN 12897 Water supply. Specification for indirectly heated unvented (closed) storage water heaters.

IGE/UP/1A,1B Strength/tightness testing and direct purging.

IGE/UP/2 Installation pipework.

IGE/UP/10 - 1 (Edition 4): Installation of gas appliances in industrial and commercial premises.

The **original** sizing tool, built with you in mind.



Size-it is quick, easy and available online on any device.

You can manage a portfolio of projects and tailor the sizing to your exact property requirements. Size-it will match the product and provide all the information and up-to-the-minute legislative guidance you need, any time, anywhere.

- Designed specifically for the UK market
- User-friendly and intuitive
- Accessible online on any device
- Up-to-date UK legislative guidance
- Manage a portfolio of projects



Register today at sizeit.co.uk

Size-it

Andrews Water Heaters range overview

Condensing



MAXXflo EVO

Delivers superior flow outputs and low NO_x for a class-leading performance, and is futureproofed with advanced BMS connectivity.



SUPAflo EVO

Produces a continuous supply of hot water and is designed for high demand environments that need high volumes of instant hot water.



ECOflo

Fully-condensing direct-fired efficient water heater suitable for large commercial properties where there's a high demand for hot water.

Non-condensing



Hiflo EVO

High efficiency floor-standing storage water heater designed for bigger applications that require larger quantities of hot water.



CLASSICflo

Standalone gas-fired water heater that can be installed on vented or unvented systems. It's quick and easy to install, particularly as a replacement for existing water heaters.



CLASSICflo FAN FLUED

Has the addition of a fan assisted flue, making them the perfect choice for installations where longer flue runs are required.



ECOflo COMPACT

High efficiency condensing floor-standing storage water heater designed to meet your toughest installation challenges and hot water demands.



COMBiflo

A range of condensing stainless-steel water heaters. With space heating capability, it produces both hot water and heating from a single heat generator and storage vessel enclosed in one cabinet.



FASTflo PLUS

Wall-hung condensing instant water heater. It's very easy to install with only three simple connections to fit.



CLASSICflo BALANCED

Offers all the advantages of the CLASSICflo but with the additional benefit of a balanced flue. The concentric flue system draws air from outside the building, making it suitable for properties where the air might be contaminated.



FASTflo

High efficiency, direct gas-fired, wall-hung continuous flow water heater, offering a very flexible, reliable and robust solution for where a continuous flow of hot water is required.



HEXflo Plate Heat Exchanger

Provides an instantaneous supply of domestic hot water to taps and showers in commercial and public sector buildings.



Sales 0345 070 1055

Technical 0345 070 1057

Web andrewswaterheaters.co.uk



Registered office address: Baxi Heating UK, Brooks House, Coventry Road, Warwick CV34 4LL

July 2019

Andrews. Built to perform.

ALL TOGETHER BETTER



BAXI HEATING COMMERCIAL BRANDS

